



Manufacturers Since 1907

BUYER'S GUIDE 2014

AMERICA'S FINEST
MATERIAL HANDLING &
STORAGE EQUIPMENT

100⁺
Celebrating
YEARS OF
Quality • Integrity • Service



WE NEVER MISS!

A PROMISED SHIPPING DATE

Visit us online at
www.meco-omaha.com

MODERN EQUIPMENT COMPANY, INC.

**ORDER
TOLL FREE
1-800-228-7334**
FAX 1-800-245-6078
E-mail: sales@meco-omaha.com



MODERN EQUIPMENT COMPANY, INC.

MANUFACTURERS OF AMERICA'S FINEST MATERIAL HANDLING & STORAGE EQUIPMENT

SINCE 1907

MECO OMAHA IS RELIABLE

- We never miss a promised shipping date—you can depend on *MECO OMAHA*
- *MECO OMAHA* sells only to dealers and distributors—overseas representation welcome
- Full two year warranty against defects—repair or replacement • **ANY** alteration to a *MECO OMAHA* product voids all warranties • *MECO OMAHA* is not responsible for the performance of any product which is improperly installed or improperly used • All rack must be installed and used in accordance with written instructions and specifications provided by *MECO OMAHA* • We do not install any product
- All welded steel construction
- Gray enamel finish used on cantilever rack • Orange enamel finish used on all other products unless otherwise specified in Buyer's Guide

MECO OMAHA IS EASY TO DO BUSINESS WITH

- Prompt shipments
- No minimum order—every order regardless of size receives personal attention
- To modify any *MECO OMAHA* product to fit your special requirements—call 1-800-228-7334 and ask us to quote • Quotation requests are answered promptly and carefully—price and delivery
- A variable steel surcharge may be applicable
- Drop shipments at no extra charge
- It is the consignee's responsibility to note "short shipments" or merchandise damaged in transit by the carrier before signing for the delivery

MECO OMAHA is not responsible for short shipments due to loss by the carrier and/or damage in transit
Freight quotations are estimates and are not binding on *MECO OMAHA*

- Weights included herein do not include pallets or packaging
- Terms: 1%—10 days, net 30 days, FOB our plant • 20% rehandling charge required on equipment returned in **saleable** condition, unless we made an error • **ANY** alteration to a *MECO OMAHA* product renders that product **unsaleable** • Such product cannot be returned for credit
- Visa® and MasterCard® accepted for net invoice amount
- Special orders may require some or all cash in advance • Normal terms for special orders are 1/3 of total invoice amount due when order is placed and specifications approved, 1/3 due before order is shipped and final 1/3 due 30 days after each shipment, subject to credit approval • Special orders are not returnable for credit
- *MECO OMAHA* is constantly striving to improve the quality of our products. As such, we may change specifications, alter designs or discontinue models at any time without notice or obligation
- All products are made in the U.S.A.

SATISFACTION GUARANTEED • WE'RE NOT SATISFIED UNTIL OUR CUSTOMER IS SATISFIED





INDEX TO BUYER'S GUIDE

DRUM HANDLING AND STORAGE EQUIPMENT pages 2-13

WIZARD • ROCK-IT • DRAINER • TANDEM • COMET • HUSTLER • CHALLENGER • ECONOMY • POLY DRUM TRUCK • POLY DRUM DRAINER TRUCK • LO-TRUCK • DRUM SKID • DRUM LIFTER • DRUM SLING • DRUM CADDY • ROUND DRUM DOLLIES • OVERPACK DRUM DOLLIES • DOUBLE DRUM DOLLIES • SOLID DECK DRUM DOLLIES • HEAVY DUTY DRUM DOLLY • 8-WHEEL DRUM DOLLY • OUTRIGGER DRUM DOLLY • TRIANGULAR DRUM DOLLY • PDR2 CART • PORTABLE DRUM RACKS • MODULAR DRUM STORAGE RACKS • DRUM STORAGE RACKS • DRUM PALLET RACKS

PALLET RACK pages 14-17

DRIVE-IN/DRIVE-THRU STRUCTURAL PALLET RACK • SELECTIVE STRUCTURAL PALLET RACK

CANTILEVER RACK. pages 19-30

WHAT IS CANTILEVER RACK? • DESIGNING A CANTILEVER RACK SYSTEM • SERIES 1000 MEDIUM DUTY • SERIES 2000 MEDIUM-HEAVY DUTY • SERIES 3000 HEAVY DUTY • SERIES 4000 STANDARD HEAVY DUTY • SERIES 5000 EXTRA HEAVY DUTY • STARTER AND ADD-ON UNITS • CANTILEVER RACK ACCESSORIES AND HEAVYWEIGHT STRUCTURAL CANTILEVER RACK

OTHER STORAGE RACKS. pages 31-34

REEL RACKS • U-RACKS • VERTICAL STORAGE RACKS • BAR STORAGE RACKS • STEEL RACKS • ROLL-OUT SHELF RACKS

HAND TRUCKS. pages 35-36

200 SERIES CONVERTIBLE 2-IN-1 TRUCK • HEAVYWEIGHT SHOVEL TRUCK • FOUR WHEEL WAREHOUSE TRUCK • 200 SERIES HAND TRUCKS • 200 SERIES HAND TRUCKS WITH STAIRGLIDES

SHELF TRUCKS, TABLES AND CARTS. pages 37-44

STEEL PARTS TRUCK • HUSKY SERVICE CART • STOCK TRUCK • INSTRUMENT CART • WELDED SERVICE CART • MOBILE STEEL TABLES • ORDER PICKING TRUCK • TOOL CART • MOBILE MACHINE TABLES • MACHINE TABLES • FIVE SHELF SERVICE CARTS • STEEL PLATFORM TRUCKS • THREE SIDED SERVICE CARTS • FOUR SHELF STOCK CART • OPEN-MESH SECURITY TRUCKS

OTHER INDUSTRIAL EQUIPMENT. pages 45-47

ADJUSTABLE PALLET STAND • REEL WINDERS • FORKLIFT PLATFORMS • FORKLIFT STOCK PICKER • BAR CRADLE TRUCKS • BAR STORAGE TRUCKS • PANEL MOVERS

HOPPERS pages 48-51

SELF DUMPING HOPPERS • SELF DUMPING HOPPER ACCESSORIES • SERIES 90 HOPPERS • LO-PROFILE HOPPER TRUCKS • STEEL TILT-HOPPER TRUCKS

CYLINDER STORAGE AND HANDLING EQUIPMENT pages 52-53

CYLINDER STORAGE CABINETS • CYLINDER PALLET RACKS • CYLINDER TRUCKS

GUARDS AND BOLLARDS pages 54-57

MACHINE, EQUIPMENT AND RACK GUARDS • STEEL SAFETY BOLLARDS • SAFETY GUARDRAILS • SQUARE TUBE SAFETY BOLLARDS • PROTECTIVE BARRIERS • MACHINERY AND RACK GUARDS • MODULAR PROTECTIVE RAILING SYSTEMS • PERIMETER GUARDS



WIZARD

FOR MIXING, DRAINING, MOVING AND STORING DRUMS

The original **MECO OMAHA** Wizard is the most versatile unit of its kind. Telescoping oak handles provide necessary leverage for easy loading when extended. Handles retract into channel frame for storage. Double welded construction. Unique button rollers attached to barrel cradles allow drum to be rotated for draining or mixing while in a horizontal position. The Wizard handles 15, 30 and 55 gallon drums weighing up to 1000 lbs. Drums must be a minimum of 29" high for the chime hook to engage the drum. The Wizard is available set up or knocked down. Knocked down models ship in a carton via UPS. All units are 18 1/2" wide; orange enamel finish.

Loading Procedure: Place Wizard toes against bottom chime with hook over top chime. Extend handles to full length. Place foot on lower axle and pull back on handles; toes will automatically slide under the drum. Move foot to upper axle and continue pulling back until all four wheels are on the floor. Retract handles and hook for storage.

• SET UP MODELS • 1000 LB CAPACITY

MODEL NO.	WHEELS	FRAME HEIGHT	DRAIN HEIGHT	LENGTH		WEIGHT
				Handles Ext.	Handles Ret.	
W12R	5" Hard Rubber	22 1/2"	20 1/2"	64"	43 1/2"	53 lbs
W12SS	4" Steel	22"	20"			51 lbs
W12P	5" Polyolefin	22 1/2"	20 1/2"			48 lbs
W12H	Replacement Oak Handle					3 lbs

• KNOCKED DOWN MODELS • 1000 LB CAPACITY

MODEL NO.	WHEELS	FRAME HEIGHT	DRAIN HEIGHT	LENGTH		WEIGHT
				Handles Ext.	Handles Ret.	
W12R-KD	5" Hard Rubber	22 1/2"	20 1/2"	64"	43 1/2"	61 lbs
W12SS-KD	4" Steel	22"	20"			59 lbs
W12P-KD	5" Polyolefin	22 1/2"	20 1/2"			56 lbs



W12P



W12P-KD

Ships in a carton via UPS

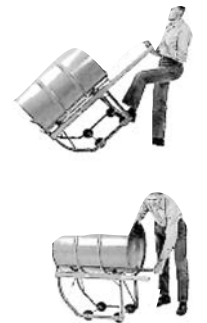

ROCK-IT

BARREL LIFT AND DRUM STAND

The most economical drum stand for draining and storing 30 gallon and 55 gallon drums. One worker can load the double welded Rock-It with safety and ease. The exclusive **MECO OMAHA** skid-resistor frame eliminates the possibility of the unit sliding away while loading, making this one of the safest units of its kind. The chime hook formed into the nose plate hooks over the barrel chime eliminating the danger of the barrel sliding off during loading. The DS1, not equipped with wheels, is ideal for inexpensive permanent storage. DS2, DSR and DSP models have two rear swivel casters and two front load wheels. Options include a handle to increase leverage while tipping the load and a slide-out drip pan to protect your floor from spills and drips. The 12" x 12" steel pan accepts most absorbent pads. Drums must be a minimum of 29" high for the handle hook to engage the drum chime. The Rock-It handles drums weighing up to 1000 lbs. All models ship set up via UPS; orange enamel finish.

• 1000 LB CAPACITY

MODEL NO.	LOAD WHEELS	SWIVEL CASTERS	LENGTH	WIDTH	HEIGHT	DRAIN HEIGHT	WEIGHT
Models Without Handle							
DS1	None	None	30"	18"	20 1/4"	18 3/4"	28 lbs
DS2	2 - 4" Steel	2 - 2 1/2" Steel		22"	20 1/4"	35 lbs	
DSR	2 - 5" Rubber	2 - 3" Polyolefin		22 1/2"	20 3/4"	36 lbs	
DSP	2 - 5" Polyolefin			34 lbs			
Models With Zinc Electro-Plated Handle							
DS1-H	None	None	36 1/2"	18"	20 1/4"	18 3/4"	33 lbs
DS2-H	2 - 4" Steel	2 - 2 1/2" Steel		22"	20 1/4"	40 lbs	
DSR-H	2 - 5" Rubber	2 - 3" Polyolefin		22 1/2"	20 3/4"	41 lbs	
DSP-H	2 - 5" Polyolefin			39 lbs			
Accessories							
DSH	Zinc plated replacement handle and hook - 36" long						5 lbs
DSDP	Drip pan - 12" x 12" I.D.						9 lbs

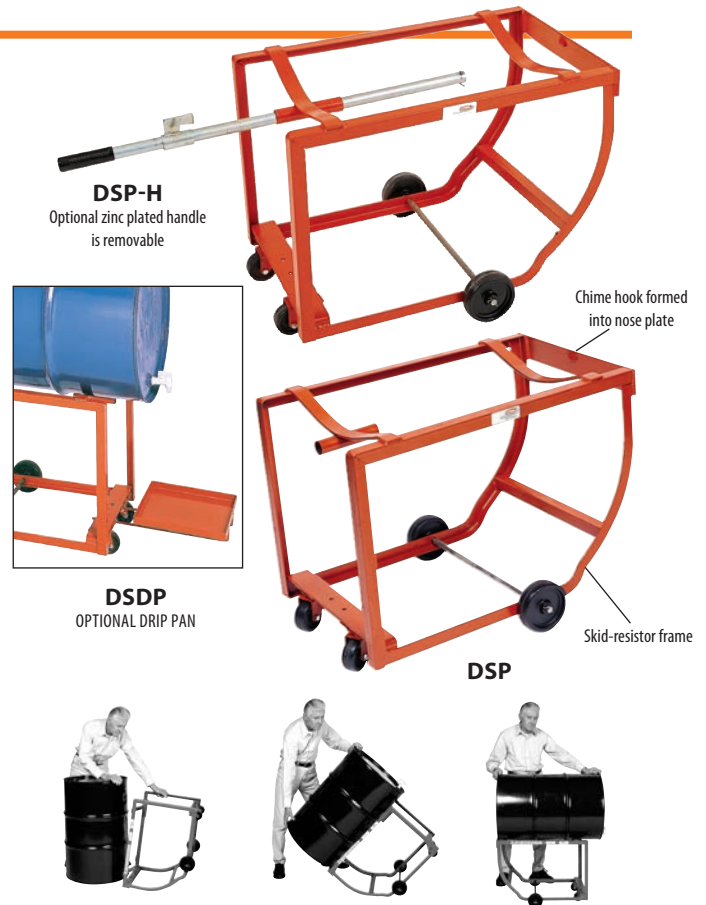

DSP-H
Optional zinc plated handle is removable

Chime hook formed into nose plate

DSDP
OPTIONAL DRIP PAN

DSP

Skid-resistor frame



Tilt drum and slide Rock-It nose under chime



Push drum back on stand and grasp top and bottom chime



Rock-It to horizontal position

ALL MODELS SHIP SET UP VIA UPS - HANDLE SHIPS IN SEPARATE BOX



DRAINER

4 WHEEL DRUM TRUCK FOR MOVING, STORING AND DISPENSING LIQUIDS

The Drainer is an original, exclusive **MECO OMAHA** design—don't settle for look-alikes. It facilitates moving and dispensing of liquids from a 55 gallon drum into a 5 gallon container and at the same time provides the convenience and ease of operation of a 4 wheel drum truck. Drain height is 14". All double welded construction and heavy duty mold-on rubber or steel wheels with roller bearings and grease fittings assure long life. The Drainer is also available with plain bore polyolefin wheels. Unique rollers on the frame allow drum rotation without removing from truck. Drum may be picked up from any side and spigot rotated to bottom from any position. Specially designed chime hook fits beneath spigot and does not interfere with dispensing operation. Use with drums between 30" and 40" in height. Unit is self-standing with the optional kickstand kit, select model number with "KS" suffix.

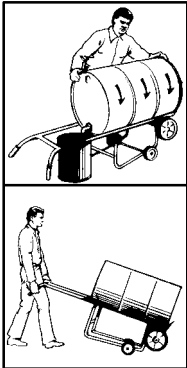

45VR
DRAINER



• 1000 LB CAPACITY

MODEL NO.	WHEELS	HEIGHT	WIDTH	WEIGHT
45VR	2 - 10" x 2 1/2" Mold-On Rubber	62"	25"	89 lbs
45VR-KS	2 - 6" x 2" Mold-On Rubber			93 lbs
45SS	2 - 10" x 2 1/2" Steel			93 lbs
45SS-KS	2 - 6" x 2" Steel			97 lbs
45P	2 - 10" x 2 1/4" Polyolefin			64 lbs
45P-KS	2 - 6" x 2" Polyolefin			68 lbs

TANDEM

HEAVY DUTY 4 WHEEL DRUM TRUCK

The Tandem is a heavy duty 4 wheel drum truck with full 1000 lb. capacity. The 1" diameter handle provides control and leverage and is double welded to the husky 1 1/4" diameter frame. The Tandem is available with mold-on rubber or steel wheels with grease fittings and roller bearings or plain bore polyolefin wheels. The replaceable chime hook assembly slides freely the full length of the hook shaft to accommodate fiber and steel drums 28" to 40" in height. Perfect balance permits easy breaking back over rear wheels; ideal for pallet loading and unloading. Truck stands upright both loaded and unloaded. An optional kickstand permits vertical out-of-the-way storage, select model number with "KS" suffix.

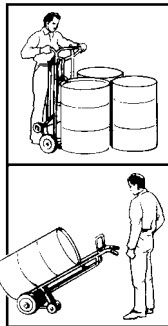

74VR
TANDEM



• 1000 LB CAPACITY

MODEL NO.	WHEELS	HEIGHT	WIDTH	WEIGHT
74VR	2 - 10" x 2 1/2" Mold-On Rubber	62"	24 1/2"	83 lbs
74VR-KS	2 - 6" x 2" Mold-On Rubber			87 lbs
74SS	2 - 10" x 2 1/2" Steel			87 lbs
74SS-KS	2 - 6" x 2" Steel			91 lbs
74P	2 - 10" x 2 1/4" Polyolefin			58 lbs
74P-KS	2 - 6" x 2" Polyolefin			62 lbs

29VR
COMET

- Replaceable chime hook assembly
- Replaceable beveled toes



COMET

THE FINEST SELF STANDING TWO HANDLE DRUM TRUCK

The Comet features a replaceable floating, spring loaded axle for ease in breaking back and will stand upright for convenient storage without a kickstand. Loads are perfectly balanced so the truck does the work—not the operator. The 1 1/4" diameter steel frame is double welded for strength. Replaceable chime hook assembly will accommodate both steel and fiber drums from 24" to 42" in height. The special beveled toes are replaceable. The 10" x 2 1/2" steel and mold-on rubber wheels have roller bearings and grease fittings. The Comet is also available with 10" plain bore polyolefin wheels.

• 1000 LB CAPACITY

MODEL NO.	WHEELS	HEIGHT	WIDTH	WEIGHT
29VR	10" x 2 1/2" Mold-On Rubber	61"	23"	81 lbs
29SS	10" x 2 1/2" Steel			84 lbs
29P	10" x 2 1/4" Polyolefin			60 lbs



HUSTLER

FOR DRUM HANDLING EASE

The Hustler Drum Truck is engineered to eliminate problems normally associated with drum handling. For example: The Hustler is equipped with a unique chime hook assembly that will handle either steel or fiber drums from 25" to 48" in height—the entire hook assembly is replaceable. The drum cradle on the Hustler is designed to provide perfect balance while loading and moving. The drum is held securely in the cradle and in the curved bar attached to the chime hook assembly. Small roller wheels are placed behind the toes to facilitate loading and unloading from pallets. The Hustler is equipped with heavy duty 10" x 2 1/2" steel or mold-on rubber wheels with roller bearings and grease fittings for long life. Also available with 10" plain bore polyolefin wheels. The 1 1/4" diameter curved handle is welded to the 1 1/2" square tube stem for years of comfortable, dependable service. The Hustler is the finest standard model drum truck available.

• 1000 LB CAPACITY

MODEL NO.	WHEELS	HEIGHT	WIDTH	WEIGHT
68VR	10" x 2 1/2" Mold-On Rubber	59"	24 1/2"	71 lbs
68SS	10" x 2 1/2" Steel			74 lbs
68P	10" x 2 1/4" Polyolefin			50 lbs

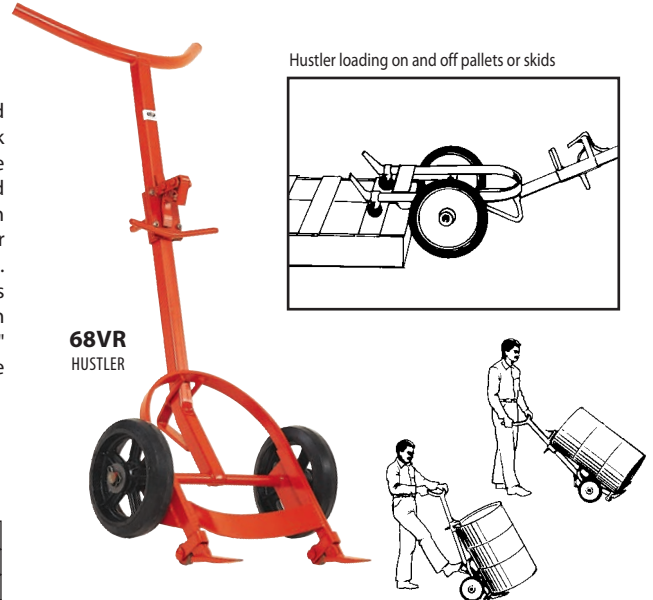

68VR
HUSTLER

CHALLENGER

SELF-STANDING • STAYS OUT OF THE WAY UNTIL YOU NEED IT

The Challenger is perfectly balanced to stand upright out of the way saving floor space and preventing tripping accidents by keeping aisles and docks clear of trucks. The Challenger is equipped with a unique chime hook assembly that will handle either steel or fiber drums from 25" to 48" in height—the entire hook assembly is replaceable. The drum cradle on the Challenger is designed to provide perfect balance for loading and moving. The drum is held securely in the cradle and in the curved bar attached to the chime hook assembly. The Challenger is equipped with heavy duty 10" x 2 1/2" steel or mold-on rubber wheels with roller bearings and grease fittings for long life. Also available with 10" plain bore polyolefin wheels. The 1 1/4" diameter curved handle is securely welded to the 1 1/2" square tube stem.

• 1000 LB CAPACITY

MODEL NO.	WHEELS	HEIGHT	WIDTH	WEIGHT
23VR	10" x 2 1/2" Mold-On Rubber	59"	24 1/2"	75 lbs
23SS	10" x 2 1/2" Steel			78 lbs
23P	10" x 2 1/4" Polyolefin			54 lbs

**LET MECO OMAHA
PUT YOUR DRUMS
ON WHEELS**

23VR
CHALLENGER
• Stands upright
• Unique design for perfect balance



ECONOMY

FOR INEXPENSIVE DRUM HANDLING

No frills, but gets the job done. **MECO OMAHA's** original design of this heavy duty drum truck keeps your costs down. Sliding chime hook adapts this truck for 30 and 55 gallon drums between 30" and 42" high. **MECO OMAHA's** high quality manufacturing touch is visible in the Economy Truck's all double welded construction. All-steel wedge toes are beveled for easy loading and securely welded to the heavy 1 1/4" diameter steel frame. Available only with 10" x 2 1/4" plain bore polyolefin wheels. Optional kickstand permits the unit to stand straight up for storage, select model number with "KS" suffix. Can ship UPS for additional savings. You will not find a better drum truck for the money.

• 1000 LB CAPACITY • UPS SHIPPABLE WITH OVERSIZE CHARGE

MODEL NO.	WHEELS	HEIGHT	WIDTH	WEIGHT
62P	10" x 2 1/4" Polyolefin	59"	25 1/2"	50 lbs
62P-KS				54 lbs



62P
ECONOMY
• Best buy for the money



POLY DRUM TRUCK

CHOOSE A UNIT FOR STANDARD POLY DRUMS OR OVERPACK DRUMS

The Poly Drum Truck features a double welded 1 1/4" diameter steel frame for years of wear. Breaking back drums is almost effortless with the replaceable floating, spring loaded axle.

Specially designed toe pads greatly minimize the chance of puncture when handling plastic or poly drums. Locking belt mechanism keeps drum safe and secure on the truck. Drum must be at least 29" in height for belt to engage. The Standard model is ideal for transporting all drums except overpacks; the Overpack model is equipped with a longer strap to handle large diameter drums such as overpacks and salvage drums.

The 10" x 2 1/2" steel and mold-on rubber wheels have roller bearings and grease fittings. Also available with 10" plain bore polyolefin wheels. Self standing for convenient storage.

29VR-1
POLY DRUM TRUCK



29VR-2
POLY DRUM TRUCK
for overpacks



• STANDARD MODEL • 1000 LB CAPACITY

MODEL NO.	WHEELS	HEIGHT	WIDTH	WEIGHT
29VR-1	10" x 2 1/2" Mold-On Rubber	61"	23"	80 lbs
29SS-1	10" x 2 1/2" Steel			83 lbs
29P-1	10" x 2 1/4" Polyolefin			58 lbs

• OVERPACK MODEL • 1000 LB CAPACITY

MODEL NO.	WHEELS	HEIGHT	WIDTH	WEIGHT
29VR-2	10" x 2 1/2" Mold-On Rubber	61"	23"	80 lbs
29SS-2	10" x 2 1/2" Steel			83 lbs
29P-2	10" x 2 1/4" Polyolefin			58 lbs

TRUCKS FOR HANDLING POLY DRUMS

POLY DRUM DRAINER TRUCK

HANDLES ALL TYPES OF DRUMS EXCEPT OVERPACKS

The Poly Drum Drainer Truck provides the convenience and ease of operation of a 4 wheel drum truck. Contents from a 55 gallon poly, fiber or metal drum can be transported and dispensed into a 5 gallon container. Drain height is 14". Chance of puncture to poly drums is minimized thanks to specially engineered toe pads. Easy-to-use safety belt system secures the drum to the truck.

Double welded steel frame for long life in an industrial environment. Mold-on rubber and steel wheels have roller bearings and grease fittings; polyolefin wheels have a plain bore.

Kickstand is included for upright storage. Not for use with overpacks.



45VR-KS-1
POLY DRUM DRAINER TRUCK

• 1000 LB CAPACITY

MODEL NO.	WHEELS	HEIGHT	WIDTH	WEIGHT
45VR-KS-1	2 - 10" x 2 1/2" Mold-On Rubber	62"	25"	89 lbs
	2 - 6" x 2" Mold-On Rubber			89 lbs
45SS-KS-1	2 - 10" x 2 1/2" Steel			93 lbs
	2 - 6" x 2" Steel			93 lbs
45P-KS-1	2 - 10" x 2 1/4" Polyolefin 2 - 6" x 2" Polyolefin	61 lbs		



LO-TRUCK

CHOICE OF HINGED, RIGID OR 3-WAY HANDLES • MOVES OPEN DRUMS WITHOUT SPILLING

The **MECO OMAHA** Lo-Truck is ideal for moving open full barrels without spilling. Heavy duty mold-on rubber, steel or polyolefin wheels with a 3" swivel caster provide smooth movement and maximum maneuverability over all types of surfaces. Smooth rolling roller bearings assure long life and effortless transportation of otherwise troublesome cargo. Polyolefin wheels have a plain bore. Select a rigid handle (LT Model), hinged handle (HLT Model) or 3-way hinged handle (CLT Model). The low profile frame, with only 1/2" of underclearance, makes loading much easier than with other higher units. All models are 33" overall width with a 27" opening width. All welded construction for longer life. For use with 55 gallon drums only.

• CLT MODELS SHIP IN A CARTON VIA UPS

MODEL NO.	RUNNING GEAR	CAPACITY	HEIGHT	WEIGHT
LT4	2 - 6" x 2" Mold-On Rubber Load Wheels	1000 lbs	31"	35 lbs
CLT4	1 - 3" Polyolefin Swivel Caster		38 1/2"	48 lbs
HLT4	1 - 3" Polyolefin Swivel Caster		37"	37 lbs
LT8	2 - 6" x 2" Steel Load Wheels	1200 lbs	31"	37 lbs
CLT8	1 - 3" Steel Swivel Caster		38 1/2"	50 lbs
HLT8	1 - 3" Steel Swivel Caster		39"	39 lbs
LTP	2 - 6" x 2" Polyolefin Load Wheels		31"	29 lbs
CLTP	1 - 3" Polyolefin Swivel Caster		38 1/2"	41 lbs
HLTP	1 - 3" Polyolefin Swivel Caster	31"	31 lbs	



LT4
RIGID HANDLE



HLT4
HINGED HANDLE



CLT4
THREE-WAY HANDLE
Folds out for pulling, folds in for shipping and storage, and locks in the vertical position for pushing

**MECO OMAHA REDUCES
MANUAL DRUM HANDLING**

DRUM SKID

A NECESSITY FOR UNLOADING DRUMS FROM ANY STANDARD TRAILER

MECO OMAHA's durable 10' Drum Skid consists of a 1 1/4" diameter frame reinforced with 1/2" solid steel round. Ideal for unloading 30 and 55 gallon drums from any standard trailer without damage to unloading areas. Eliminates punctured drums. No more spillage from jarred plugs or damaged chimes. Toe plate is mounted at the correct angle to ensure proper impact point. A 1/4" high-test chain with grab hook is provided to secure skid to trailer.



SK10

• 1000 LB CAPACITY

MODEL NO.	LENGTH	WIDTH		WEIGHT
SK10	120"	Outside 15 3/8"	Inside 12 1/2"	75 lbs



DL1
DRUM LIFTER

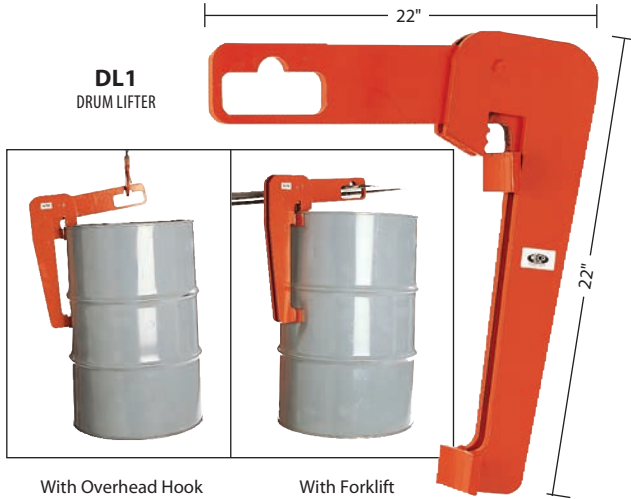

DRUM LIFTER

EASY TO USE WITH FORKLIFT OR HOOK

The Drum Lifter is designed for no-tilt lifting of open or closed head drums with or without tops in place. Our self adjusting Drum Lifter instantly adapts to individual drum loads with its unique compressing action. The heavier your drum, the tighter our lifter will grip. Simple enough for use by one person with any overhead lifting system. Opening for forklift tine or hook attachment is 2 1/2" x 5". For use with steel drums only.

• SHIPS IN A CARTON VIA UPS

MODEL NO.	CAPACITY	WEIGHT
DL1	3000 lbs	45 lbs

SL1
DRUM SLING

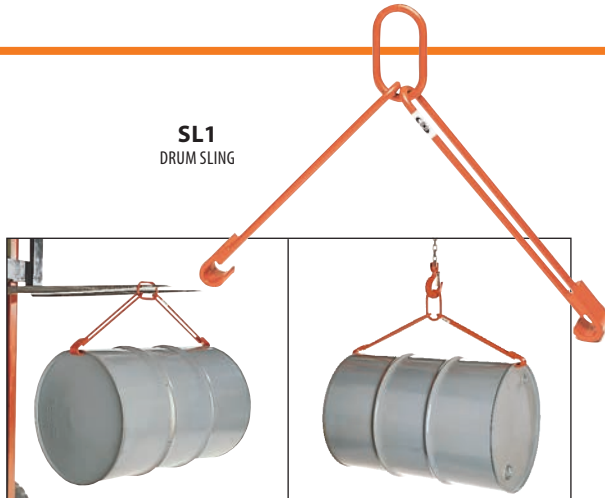

DRUM SLING

SIMPLIFIES LIFTING HORIZONTAL DRUMS

Lift 55 gallon drums from the horizontal position with our **MECO OMAHA** Drum Sling. This simple and effective Drum Sling consists of two 18 1/2" legs of 1/2" steel round bar with a 1000 lb. capacity. The Drum Sling is strong enough for your heaviest drums. The 3" x 6" steel lifting ring is designed to handle hooks of all standard overhead lifting systems. Lifting ring also accommodates 4" forklift tines. For use with steel drums only.

• SHIPS IN A CARTON VIA UPS

MODEL NO.	CAPACITY	WEIGHT
SL1	1000 lbs	7 lbs

DC55
DRUM CADDY



DRUM CADDY

FOR DRUM HANDLING EASE WITH FORKLIFT

MECO OMAHA Drum Caddies allow you to transport drums with your forklift. This simple and inexpensive piece of equipment is designed for safety. The manual handling of drums is greatly reduced. Steel band slips over your drum and is fastened with a specially designed overcenter latch. Unique 5" x 3" pivoting fork stirrups will allow you to tilt your drums for ease of dispensing. For use with steel drums only.

• SHIPS IN A CARTON VIA UPS

MODEL NO.	DRUM SIZE	CAPACITY	WEIGHT
DC30	30 Gallon 18"-18 1/2" diameter	1000 lbs	18 lbs
DC55	55 Gallon 22"-22 1/2" diameter		20 lbs



ROUND DRUM DOLLIES

FOR 30 OR 55 GALLON DRUMS

MECO OMAHA Drum Dollies save time, money and effort by making your drums mobile. Four heavy duty swivel casters allow drums to turn 360 degrees for maximum maneuverability—casters are welded to frame for greater strength. Choice of 2 1/2" or 3" polyolefin or steel wheels. Designed for optimum stability with casters inside frame to prevent breaking. Outside ring extends above cross frame so that drum sets into dolly preventing container from slipping—drum is 4" off floor with 3" casters; 3 3/4" off floor with 2 1/2" casters. Can be used to transport full drums or make empty drums mobile. Ideal for converting empty drums into mobile refuse containers.

• SHIPS IN A CARTON VIA UPS

MODEL NO.	DRUM SIZE	I.D.	SWIVEL CASTERS	HEIGHT	CAPACITY	WEIGHT
433R	30 Gallon	19 1/4"	3" Polyolefin	5 1/2"	900 lbs	19 lbs
433S			3" Steel		1200 lbs	22 lbs
434R			2 1/2" Polyolefin	5 1/4"	700 lbs	19 lbs
434S			2 1/2" Steel		900 lbs	21 lbs
435R	55 Gallon	23 1/4"	2 1/2" Polyolefin	5 1/4"	700 lbs	22 lbs
435S			2 1/2" Steel		900 lbs	24 lbs
436R			3" Polyolefin	5 1/2"	900 lbs	22 lbs
436S			3" Steel		1200 lbs	25 lbs

436R
ROUND DRUM DOLLY



OVERPACK DRUM DOLLIES

FOR LOW COST TRANSPORT OF OVERPACK AND SALVAGE DRUMS

The **MECO OMAHA** Overpack Drum Dolly safely contains a wide variety of steel and poly drums within a 2 1/2" deep ring. Drum is only 4" off floor for maximum stability. Four 3" swivel casters ensure complete maneuverability—choice of polyolefin or steel wheels. Orange enamel finish; 27" inside diameter.

• SHIPS IN A CARTON VIA UPS

MODEL NO.	SWIVEL CASTERS	HEIGHT	CAPACITY	WEIGHT
437P	3" Polyolefin	5 1/2"	900 lbs	24 lbs
437S	3" Steel		1200 lbs	28 lbs

27" I.D.



437P
OVERPACK DRUM DOLLY

DOUBLE DRUM DOLLIES

MOVE TWO 30 OR 55 GALLON DRUMS AT A TIME • DOUBLE YOUR EFFICIENCY

The Double Drum Dolly from **MECO OMAHA** enables a worker to move two drums at a time instead of one—productivity is increased! Drums are contained safely and securely within a 2 1/2" deep ring. Four 3" steel cross strips support the load; a 2 1/2" wide lengthwise strip with a steel angle stiffener increases rigidity and reduces flex under load. Drum is only 5 1/4" off floor. Six double ball race swivel casters provide 1800 lbs. capacity and ensure total maneuverability. Orange enamel finish.

• SHIPS IN A CARTON VIA UPS

MODEL NO.	DRUM SIZE	DIMENSIONS L x W x H	SWIVEL CASTERS	CAPACITY	WEIGHT
866P	30 Gallon	40" x 19 1/2" x 6 3/4"	4" Polyolefin	1800 lbs	45 lbs
872P	55 Gallon	48" x 23 1/2" x 6 3/4"			51 lbs

872P
DOUBLE DRUM DOLLY





SOLID DECK DRUM DOLLIES

- Solid Deck Provides Great Overall Support
- Deck With Lip Retains the Load
- Four Heavy Duty Swivel Casters For Maximum Maneuverability
- Casters Welded to the Frame for Great Strength
- Drum is 3⁵/₈" Off Floor with 2¹/₂" Casters
- Drum is 3⁷/₈" Off Floor with 3" Casters
- Orange Enamel Finish



SDD55R-H



SDD5P



SDD55R

• SHIPS IN A CARTON VIA UPS - HANDLE SHIPS IN SEPARATE BOX

MODEL NO.	DRUM SIZE	I.D.	SWIVEL CASTERS	HEIGHT	CAPACITY	WEIGHT
SDD5P	5 gal.	12 ¹ / ₈ "	2 ¹ / ₂ " Polyolefin	6 ¹ / ₈ "	700 lbs	37 lbs
SDD55R	55 gal.	23 ¹ / ₄ "	3" Hard Rubber	5 ³ / ₈ "	900 lbs	28 lbs
SDD55S	55 gal.	23 ¹ / ₄ "	3" Steel	5 ³ / ₈ "	900 lbs	32 lbs
SDD85P	85 gal.	28 ⁷ / ₈ "	3" Polyolefin	5 ³ / ₈ "	900 lbs	38 lbs

• MODELS WITH ZINC ELECTRO-PLATED HANDLE

MODEL NO.	DRUM SIZE	I.D.	SWIVEL CASTERS	HEIGHT	CAPACITY	WEIGHT
SDD55R-H	55 gal.	23 ¹ / ₄ "	3" Hard Rubber	5 ³ / ₈ "	900 lbs	30 lbs
SDD55S-H	55 gal.	23 ¹ / ₄ "	3" Hard Steel	5 ³ / ₈ "	900 lbs	34 lbs

MODEL NO.	DESCRIPTION	SWIVEL CASTERS	COATING	WEIGHT
DTH	Replacement Handle	3/8" x 35" L	Zinc Plated	2 lbs

HEAVY DUTY DRUM DOLLY
TRANSPORTS LOADS UP TO 2000 LBS.

- All Welded Steel Construction
- 25¹/₄" Diameter x 7¹/₈" Height Overall
- Orange Enamel Finish
- Fits Drum Capacity 55 Gallon
- 23¹/₄" Inside Diameter
- Swivel Caster Includes Brake
- Drum is 5⁵/₈" Off Floor



HDD-55PHL

• SHIPS IN A CARTON VIA UPS

MODEL NO.	DRUM SIZE	SWIVEL CASTERS	HEIGHT	LENGTH	CAPACITY	WEIGHT
HDD-55PHL	55 gal.	4" Phenolic	7 ¹ / ₈ "	25 ¹ / ₄ "	2,000 lbs	32 lbs

836S



8-WHEEL DRUM DOLLY

HAS A UNIQUE DESIGN THAT FEATURES EIGHT CASTERS THAT SMOOTHLY TRANSPORT YOUR LOAD

- All Welded Steel Construction
- 26⁷/₈" Diameter x 7" Height Overall
- Orange Enamel Finish
- Fits Drum Capacity 55 Gallon
- 24" Inside Diameter
- Drum is 5¹/₈" Off Floor



• SHIPS IN A CARTON VIA UPS

MODEL NO.	DRUM SIZE	SWIVEL CASTERS	HEIGHT	LENGTH	CAPACITY	WEIGHT
836S	55 gal.	4" Steel	7"	26 ⁷ / ₈ "	2,000 lbs	34 lbs



OUTRIGGER DRUM DOLLY

SAVE TIME, MONEY AND EFFORT BY MAKING DRUMS MOBILE

- Protective Steel Outriggers Over Each Caster
- Double-Welded Steel Frame With a 2½" Deep Lip
- Four Heavy Duty Swivel Casters Permit 360 Degree Maneuverability
- Casters Are Welded to the Frame for Greater Strength
- Orange Enamel Finish
- Drum is 3⅞" Off Floor



536-RG
OUTRIGGER DRUM DOLLY

• SHIPS IN A CARTON VIA UPS

MODEL NO.	DRUM SIZE	I.D.	SWIVEL CASTERS	HEIGHT	CAPACITY	WEIGHT
536-RG	55 gal.	23¼"	3" Polyolefin	6½"	900 lbs	22 lbs

WE NEVER MISS



A PROMISED SHIPPING DATE!

CALL TODAY FOR YOUR PROMISED DATE!

800-228-7334



TRIANGULAR DRUM DOLLY
 LOW-PROFILE DESIGN MAKES LOADING AND UNLOADING SAFE AND EASY

- 3/8" Thick Steel Construction For Years of Industrial Use
- Drum Safely Rests 1" Above the Floor
- Ready To Use - No Assembly Required
- Casters Are Bolted to the Frame for Easy Replacement
- Orange Enamel Finish

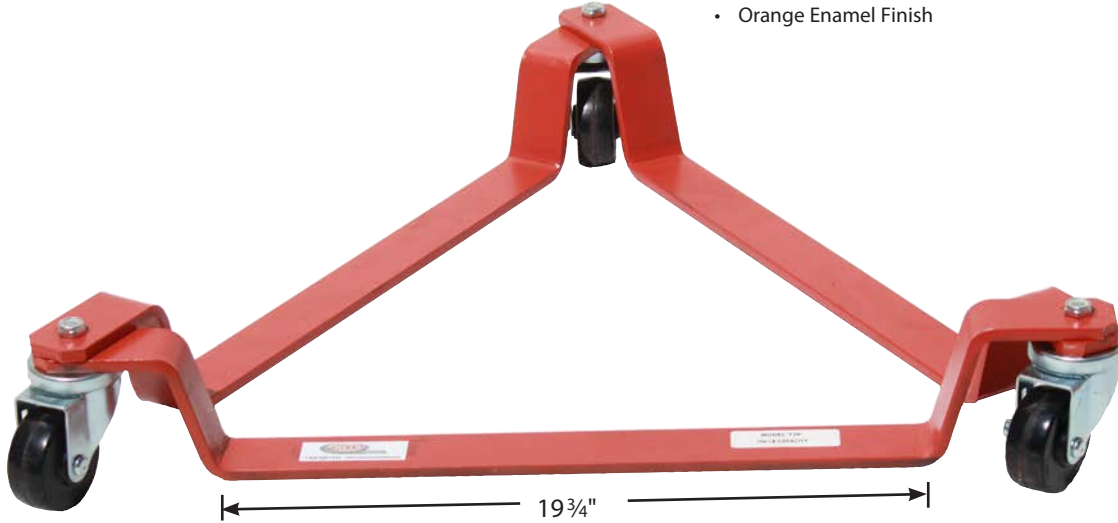

• SHIPS IN A CARTON VIA UPS

MODEL NO.	DRUM SIZE	SWIVEL CASTERS	HEIGHT	CAPACITY	WEIGHT
T3P	55 gal.	3" Polyolefin	5 1/4"	700 lbs	25 lbs

DRUM RACK AND DRUM NOT INCLUDED
 SEE PAGE 12 FOR DRUM RACK



PDR2 CART
 MAKES YOUR TWO DRUM RACK PORTABLE WITHOUT POWERED EQUIPMENT

- For Use With Model PDR or Model PDR2-KD
- Vertical Legs are Fabricated from 2" Square Steel Tube; Horizontal Members are Fabricated from Heavy Wall Rectangular Tubing
- Drum Rack Fits Snugly and Safely Within the Four Corner Target Guides
- PDR2 Cart Provides a Convenient 25 1/2" Pouring Height
- Orange Enamel Finish



• SHIPS KNOCKED DOWN IN A CARTON VIA UPS

MODEL NO.	SWIVEL CASTERS	HEIGHT	LENGTH	DEPTH	CAPACITY	WEIGHT
PS-2DR	5" x 2" Phenolic 2 Swivel/2 Rigid	19"	46"	30"	1,800 lbs	75 lbs



PORTABLE DRUM RACKS

MECO OMAHA RACKS SAVE SPACE AND MONEY • CHOICE OF ALL WELDED OR KNOCKED DOWN CONSTRUCTION

MECO OMAHA's all welded Portable Drum Racks allow use of forklift to move and store drums—saving time and manpower. Formed drum cradles of 1/4" steel bar, heavy wall rectangular steel tubing horizontal frame and square tubing cross supports combine to make these units almost indestructible. Individual drum racks may be shipped assembled ready for use or shipped knocked down via UPS. Racks stack four high. Two drum unit has 1600 lbs. capacity and a stacked capacity of 6400 lbs. Three drum unit has 2400 lbs. capacity and a stacked capacity of 9600 lbs. Two drum models have four-way forklift access; three drum models have two-way access, front and rear. Center to center of drum cradles is 26".

SEE PAGE 11 FOR
PDR2 CART

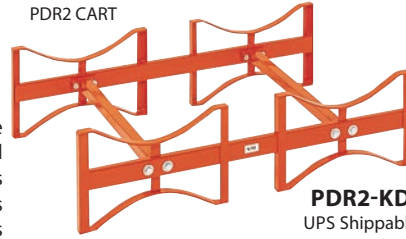

PDR2-KD
UPS Shippable

All welded PDR2 is identical except for bolts

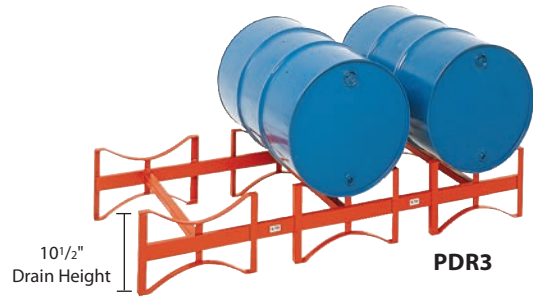

10 1/2"
Drain Height

PDR3

NOTE: Due to increased length of the three drum models, it is recommended that they not be moved stacked more than two racks high. Movement of more than two racks high could create an unbalanced condition.

• SET UP MODELS

MODEL NO.	HEIGHT	LENGTH	DEPTH	WEIGHT
PDR2	12 1/2"	45 1/2"	30"	45 lbs
PDR3		71 1/2"		70 lbs

• KNOCKED DOWN MODELS • SHIP IN A CARTON VIA UPS*

MODEL NO.	HEIGHT	LENGTH	DEPTH	WEIGHT
PDR2-KD	12 1/2"	45 1/2"	30"	51 lbs
PDR3-KD		71 1/2"		76 lbs

*PDR3-KD SHIPS IN TWO CARTONS

MODULAR DRUM STORAGE RACKS

FLEXIBLE SYSTEM • NO TOOLS OR HARDWARE REQUIRED • DISPENSE FROM LOWER LEVEL • STACK 5 HIGH

Each of the four MECO OMAHA Modular Drum Storage Racks can be used individually or can be easily stacked up to five levels high by using connector posts. No tools or fasteners are needed. Constructed of heavy duty, all double welded steel for durability. Designed for convenient forklift entry front and rear. Drums can be removed or replaced without disturbing other drums in the racks. Height from floor to top of first level is 7 1/2" when used without socket feet or connector posts.

Draining liquid from drums on the lower level is easy. Simply use the MDRF2 socket feet to raise each rack so the lower level is 16" high for draining into a 5 gallon pail.

• HIGH VISIBILITY ORANGE ENAMEL FINISH

MODEL NO.	NO. OF DRUMS	HEIGHT	WIDTH	DEPTH	CAPACITY PER LEVEL	WEIGHT
MDR1	1	12 1/2"	35"	36"	1500 lbs	28 lbs
MDR2W	2		61"		2000 lbs	47 lbs
MDR2D			35"	72"	54 lbs	
MDR4	4		61"		2800 lbs	92 lbs
MDRP (Set of 4)		30"				21 lbs
MDRF1 (Set of 4)		4 1/2"				7 lbs
MDRF2 (Set of 4)		13 1/2"				13 lbs

MDR1



7 1/2"

MDR1

MDRP

MDR1

MDRF2



2 drum storage unit made up of two MDR1 racks with posts and feet

MDR2D

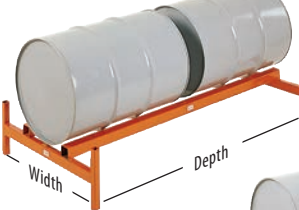

Width

Depth



MDR4



MDRP

30" connector posts are used to stack Modular Drum Storage Racks up to 5 levels high.

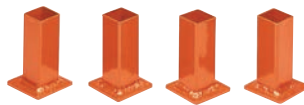

MDRF1

Socket feet have 3" square floor plates for use on resilient or uneven floors or when stacking more than 3 levels high. 4 1/2" in height.

MDRF2 Socket feet easily mount on **MDR2W**. No tools or fasteners needed to add feet or posts to Modular Drum Storage Racks. **MDRF2** socket feet have 3" square floor plates and are 13 1/2" in height.



MDR2W



DR3
3 DRUM RACK



DR4
4 DRUM RACK



DR9
9 DRUM RACK



DR6-3H
6 DRUM RACK

DRUM STORAGE RACKS

PERMANENT STORAGE RACKS SHIPPED KNOCKED DOWN WITH COMPLETE INSTRUCTIONS FOR EASY ASSEMBLY

MECO OMAHA Drum Storage Racks are constructed of heavy duty steel angle and engineered for orderly handling and selective storage and removal of 30 and 55 gallon drums. Assembly is easy—simply bolt four vertical legs to individual levels, attach X-bracing to ends and rack is ready to accept drums. For maximum flexibility in drum storage, racks may be ordered to permit back to back installation allowing the user to customize every system to his own requirement. By combining units, any degree of capacity in nearly any type of space can be obtained. Designed for convenient forklift entry front and rear; all units are 34" deep.

• SHIPS KNOCKED DOWN IN A CARTON

MODEL NO.	NO. OF LEVELS	HEIGHT TO TOP OF FIRST LEVEL	HEIGHT	WIDTH	CAPACITY	WEIGHT
DR3	3	8 1/2"	70"	33"	2400 lbs	163 lbs
DR4	2	18"	48 1/2"	60"	3200 lbs	162 lbs
DR6-2H				85 1/2"	4800 lbs	210 lbs
DR6-3H	3	8 1/2"	70"	60"	7200 lbs	230 lbs
DR9				85 1/2"		302 lbs

LET MECO OMAHA SOLVE YOUR DRUM STORAGE PROBLEMS

DPR12
12 DRUM PALLET RACK



DRUM PALLET RACKS

HEAVY DUTY • VERSATILE RACK FOR DRUM OR PALLET STORAGE

Satisfy your high capacity drum storage requirements with the MECO OMAHA Drum Pallet Rack. Designed to store 30 and 55 gallon drums; accepts 12 or 16 drums depending upon model. Each level has a capacity of 4825 lbs.

Rack is easy to assemble by bolting the load beams to the all welded 3" structural channel upright frame—no special tools required. Frames are punched full height on 4" centers permitting 2" vertical adjustability of beams.

The portable drum cradles are made of 1 1/4" diameter tubing to prevent premature drum wear and can be positioned on the load beams to meet user requirements. Cradles are included with the rack. Drum cradles can be removed from any level to allow storage of palletized material.

Add-on units of one upright frame, load beams and cradles can be ordered. Additional cradles can be ordered separately.

Gray enamel finish.

• SHIPS KNOCKED DOWN • ALL UNITS 36" DEEP

MODEL NO.	TYPE	DESCRIPTION	HEIGHT	WIDTH	CAPACITY	WEIGHT
DPR12	3 Level	Starter	84"	105"	14,475 lbs	480 lbs
DPR12-A	12 Drum	Add-On		102"		417 lbs
DPR16	4 Level	Starter	120"	105"	19,300 lbs	655 lbs
DPR16-A	16 Drum	Add-On		102"		563 lbs
DPRC		Drum Cradle		12"	800 lbs	11 lbs



DRIVE-IN/DRIVE-THRU STRUCTURAL PALLET RACK

THE MOST EFFICIENT METHOD TO STORE LARGE QUANTITIES OF SIMILAR PALLET LOADS



MECO OMAHA Drive-in Rack installation. Custom-designed for high density storage and efficient handling.

Satisfy your high density bulk storage requirements with a drive-in/ drive-thru system from **MECO OMAHA**. Drive-in systems allow forklift entry from one direction only—ideal for a first in/last out inventory system. Drive-thru systems allow the forklift to enter the rack from either the front or rear and move pallets completely through the structure. This system works best in a first in/first out system. Both drive-in and drive-thru racks reduce the need for conventional aisle space and maximize warehouse utilization.

MECO OMAHA drive-in/drive-thru racks are custom designed to fit your specific storage application. Upright frames, pallet support beams and cross ties are fabricated from structural channel providing optimum strength and durability. Upright frames are punched on 4"

centers, special bracket allows 2" vertical adjustability of rail supports. Structural angle load rails are mounted to rail supports by a special bracket eliminating screws or bolts on the rail surface—pallets cannot be damaged by obstructions. All connections are accomplished with plated, heavy duty bolts and nuts—cannot be dislodged by forklift impact; installation is fast and easy with no special tools required.

Contact your **MECO OMAHA** representative for custom-designed drive-in or drive-thru rack systems.

MECO OMAHA sells drive-in/drive-thru structural pallet rack to approved dealers only.



Similar pallet loads are stored neatly and efficiently in a three-high, five deep system.



SELECTIVE STRUCTURAL PALLET RACK

- BUILT FOR LONG-LASTING PERFORMANCE
- INCREASED RESISTANCE TO FORKLIFT DAMAGE DUE TO THICKER CROSS-SECTION OF STRUCTURAL MEMBERS

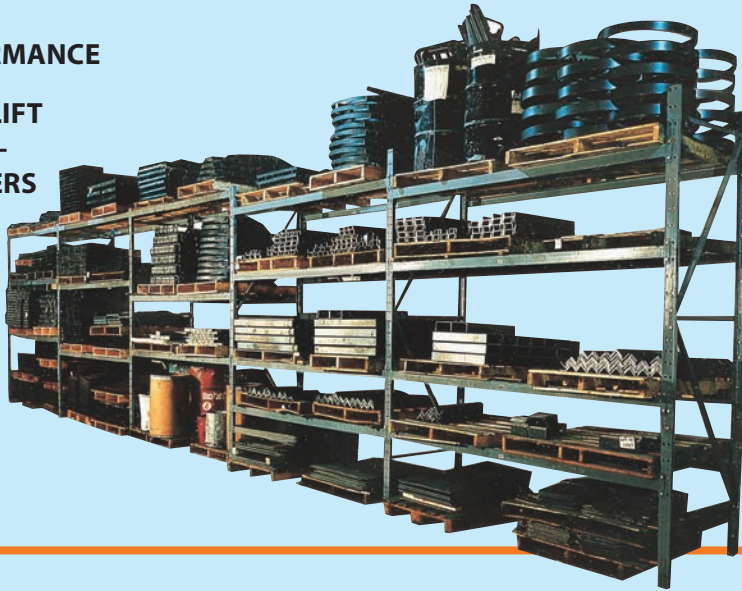

MECO OMAHA Structural Pallet Rack is designed in accordance with AISC and RMI Standards. Upright frames and load beams are fabricated from structural channel with a minimum yield of 36,000 PSI. Beams are secured to the upright frames with plated, heavy duty bolts and nuts—cannot be dislodged by forklift impact; installation is fast and easy with no special tools required.

A wide range of frame heights, depths, beam lengths and load capacities is available to meet the most demanding storage requirements. Custom pallet rack is designed by a dedicated engineering staff using state-of-the-art CAD technology and years of experience.

UPRIGHT FRAMES • Rigid, all-welded uprights provide storage capacity up to 52,200 lbs. per frame. Select the height of upright frames according to existing ceiling heights, sprinkler systems, and forklift limitations. Frame depth is determined by the length of the pallet: Standard pallet overhang is 3" front and back. The stated capacity of upright frames is based on a maximum vertical

beam spacing of 60". A vertical beam spacing of less than 60" will result in the same stated capacity. The vertical beam spacing includes the distance from the floor to the top of the lowest pair of load beams. If a vertical beam spacing greater than 60" is required, contact your **MECO OMAHA** representative to determine upright frame capacity. Frames are punched on 4" centers for maximum beam adjustability.

LOAD BEAMS • Special bracket allows 2" adjustability up and down the frame. When selecting the appropriate beam length, add a minimum of 10" to two pallet widths or 14" to three pallet widths. Additional spacing may be required for pallets with excessive load overhang. Using the Load Beam Table of Capacity, select the pair of beams of the proper length and capacity making sure not to overload the beams. **NOTE:** Capacities are based on a uniformly distributed load over a pair of beams and are in accordance with AISC and RMI Standards. Deflection does not exceed 1/180 of the beam length. Load beams and related beam braces are sold as an integral unit.

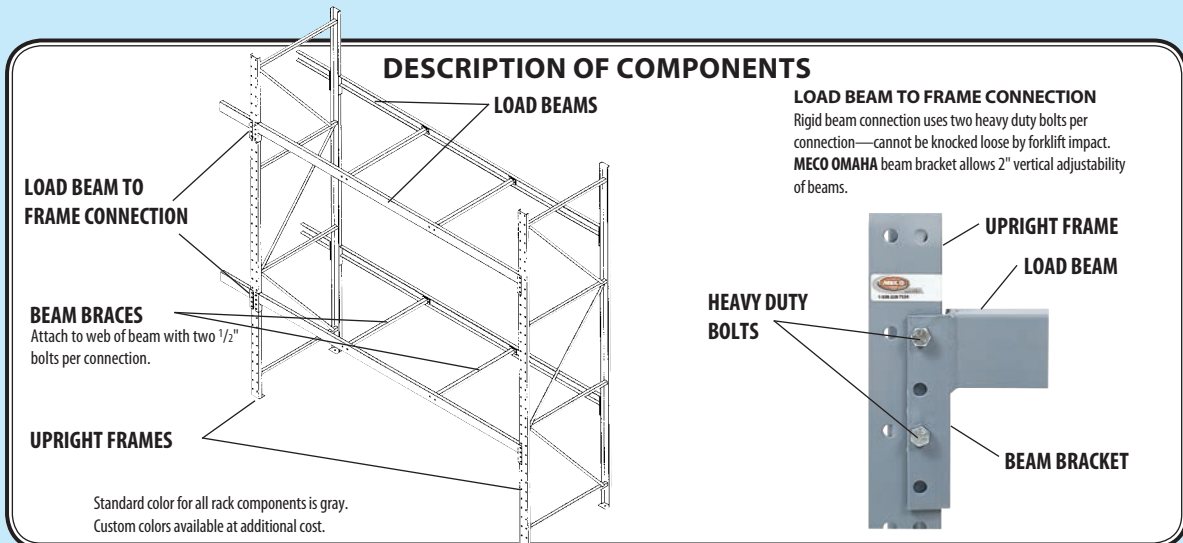



SELECTIVE STRUCTURE

UPRIGHT FRAMES

• STRUCTURAL CHANNEL UPRIGHT FRAMES

DEPTH OF FRAME	HEIGHT OF FRAME	3" CHANNEL • 34,800 LBS CAPACITY PER FRAME*		4" CHANNEL • 52,200 LBS CAPACITY PER FRAME*	
		MODEL NO.	WEIGHT (LBS)	MODEL NO.	WEIGHT (LBS)
36"	8'	SF3-3608	70	SF4-3608	104
	10'	SF3-3610	92	SF4-3610	134
	12'	SF3-3612	124	SF4-3612	161
	14'	SF3-3614	144	SF4-3614	187
	15'	SF3-3615	152	SF4-3615	197
	16'	SF3-3616	165	SF4-3616	214
	18'	SF3-3618	184	SF4-3618	239
	20'	SF3-3620	208	SF4-3620	270
	22'	SF3-3622	224	SF4-3622	291
	24'	SF3-3624	248	SF4-3624	322
42"	8'	SF3-4208	72	SF4-4208	106
	10'	SF3-4210	95	SF4-4210	137
	12'	SF3-4212	127	SF4-4212	165
	14'	SF3-4214	148	SF4-4214	191
	15'	SF3-4215	155	SF4-4215	201
	16'	SF3-4216	169	SF4-4216	219
	18'	SF3-4218	188	SF4-4218	244
	20'	SF3-4220	213	SF4-4220	275
	22'	SF3-4222	229	SF4-4222	297
	24'	SF3-4224	254	SF4-4224	328
48"	8'	SF3-4808	74	SF4-4808	108
	10'	SF3-4810	97	SF4-4810	141
	12'	SF3-4812	130	SF4-4812	169
	14'	SF3-4814	151	SF4-4814	195
	15'	SF3-4815	159	SF4-4815	206
	16'	SF3-4816	172	SF4-4816	222
	18'	SF3-4818	193	SF4-4818	249
	20'	SF3-4820	218	SF4-4820	282
	22'	SF3-4822	234	SF4-4822	304
	24'	SF3-4824	260	SF4-4824	336

* BASED ON A MAXIMUM VERTICAL BEAM SPACING OF 60"

STRUCTURAL RACK ACCESSORIES

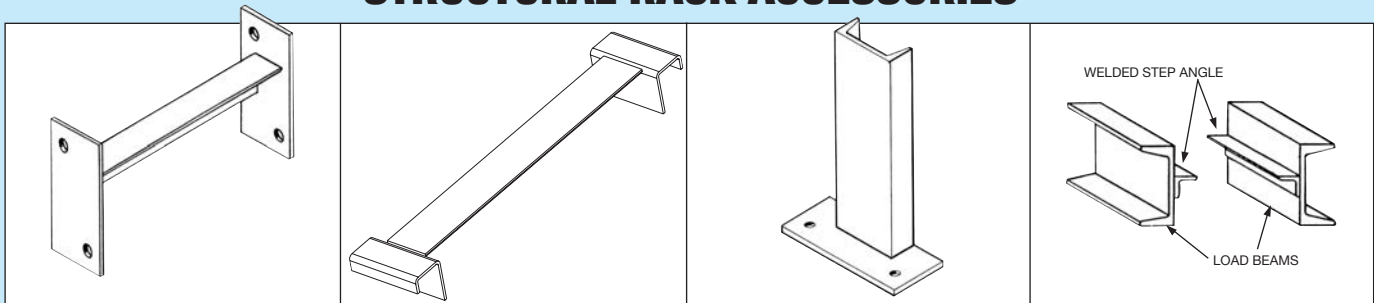

WALL TIES AND ROW SPACERS
 permit linking a row of racks to either the wall or a back-to-back row of racks. Maintain spacing while providing additional stability to the system.

PALLET SUPPORTS
 prevent undersized loads from falling through the beams, support weak pallets or serve as a deck support. Both drop-in and bolted models are available.

STRUCTURAL POST PROTECTORS
 provide extra protection from forklift abuse in the lower frame areas.

LOAD BEAMS WITH STEP ANGLE
 permit a custom deck to be placed in the pallet rack system for added versatility. Step angle is factory welded to the inside of the load beam at custom heights to meet individual requirements.

Other popular accessories such as fork clearance bars, skid channels, steel decks and drum cradles are available.
Contact your MECO OMAHA representative.



URAL PALLET RACK

LOAD BEAMS

• STRUCTURAL CHANNEL LOAD BEAMS (LOAD BEAMS AND RELATED BEAM BRACES ARE SOLD AS AN INTEGRAL UNIT)

LENGTH OF BEAMS	3" CHANNEL (PER PAIR)				4" CHANNEL (PER PAIR)				5" CHANNEL (PER PAIR)				
	NO. OF BEAM BRACES	BEAM BRACE LENGTH	MODEL NO.	WEIGHT (LBS)	NO. OF BEAM BRACES	BEAM BRACE LENGTH	MODEL NO.	WEIGHT (LBS)	NO. OF BEAM BRACES	BEAM BRACE LENGTH	MODEL NO.	WEIGHT (LBS)	
48"	0	-	2SB3-48	38	0	-	2SB4-48	48	0	-	2SB5-48	58	
54"			2SB3-54	42			2SB4-54	54			2SB5-54	66	
60"			2SB3-60	46			2SB4-60	60			2SB5-60	72	
66"			2SB3-66	50			2SB4-66	64			2SB5-66	78	
72"			2SB3-72	54			2SB4-72	70			2SB5-72	86	
84"	0	-	2SB3-84	62	1	36"	2SB4-84-36	87	1	36"	2SB5-84-36	107	
96"						42"	2SB4-84-42	88		42"	2SB5-84-42	108	
						48"	2SB4-84-48	89		48"	2SB5-84-48	109	
108"	1	-	2SB3-96	70	1	36"	2SB4-96-36	99	1	36"	2SB5-96-36	119	
						42"	2SB4-96-42	100		42"	2SB5-96-42	120	
						48"	2SB4-96-48	101		48"	2SB5-96-48	121	
120"	1	36"	2SB3-108-36	87	1	36"	2SB4-108-36	109	1	36"	2SB5-108-36	133	
		42"	2SB3-108-42	88		42"	2SB4-108-42	110		42"	2SB5-108-42	134	
		48"	2SB3-108-48	89		48"	2SB4-108-48	111		48"	2SB5-108-48	135	
132"	2	-	36"	2SB3-120-36	95	2	36"	2SB4-120-236	128	2	36"	2SB5-120-236	154
			42"	2SB3-120-42	96		42"	2SB4-120-242	130		42"	2SB5-120-242	156
			48"	2SB3-120-48	97		48"	2SB4-120-248	132		48"	2SB5-120-248	158
144"	2	-	36"	2SB3-132-236	110	2	36"	2SB4-132-236	138	2	36"	2SB5-132-236	166
			42"	2SB3-132-242	112		42"	2SB4-132-242	140		42"	2SB5-132-242	168
			48"	2SB3-132-248	114		48"	2SB4-132-248	142		48"	2SB5-132-248	170
144"	2	-	36"	2SB3-144-236	118	2	36"	2SB4-144-236	150	2	36"	2SB5-144-236	190
			42"	2SB3-144-242	120		42"	2SB4-144-242	152		42"	2SB5-144-242	192
			48"	2SB3-144-248	122		48"	2SB4-144-248	154		48"	2SB5-144-248	194

LOAD BEAMS • TABLE OF CAPACITY

• CAPACITIES ARE BASED ON A UNIFORMLY DISTRIBUTED LOAD OVER A PAIR OF BEAMS

LENGTH OF BEAMS	CAPACITY PER PAIR OF BEAMS (LBS)		
	3" CHANNEL (2SB3)	4" CHANNEL (2SB4)	5" CHANNEL (2SB5)
48"	10,000	17,500	26,000
54"	8,800	15,500	23,000
60"	8,000	14,000	20,000
66"	7,250	12,500	18,000
72"	6,750	11,500	16,750
84"	5,750	10,000	15,750
96"	5,000	8,750	13,750
108"	4,300	7,750	12,250
120"	3,850	7,000	11,000
132"	3,350	6,100	10,000
144"	3,000	5,600	9,000

Special label requirements can be met at additional cost.



MANUFACTURER OF AMERICA'S FINEST MATERIAL HANDLING & STORAGE EQUIPMENT SINCE 1907



*Just a sample of what
Quality, Integrity & Service
can accomplish.*





MECO OMAHA CANTILEVER RACK

SERIES 1000 THROUGH SERIES 5000

• MECO OMAHA CANTILEVER RACK FOR A NEAT AND ORDERLY INVENTORY SYSTEM



- INSTANT ACCESSIBILITY TO ONE PIECE OR A FULL LOAD
- FAST, CONVENIENT HANDLING OF LONG, UNWIELDY STOCK

FOR STORAGE AND EASY SELECTION OF BAR STOCK, PIPE, STRUCTURALS, TUBING AND OTHER LONG ITEMS OR WHERE UNINTERRUPTED DECKING IS REQUIRED.

MECO OMAHA manufactures five basic capacity series to fit your storage requirements – from Series 1000 Medium Duty through the Series 5000 Extra Heavy Duty.

Available in upright heights from 6' to 20' with 2' through 10' brace widths (measured on center). Arms are completely adjustable on 3" centers to accommodate an infinite variety of items. Straight arms are available in nine different lengths with or without lips. Heavy Duty and Extra Heavy Duty arms are both available in seven lengths with or without lips. Inclined arms are available in seven lengths with or without lips. A wide range of base sizes allows custom designing of rack systems to your individual needs. Uprights are punched on both sides for versatility and can be used single sided or double sided depending on the size of base used. Note that arms must never be placed on the back side of a single-based upright.

MECO OMAHA CANTILEVER RACKS are modular within each basic capacity series so that additional arms, uprights and cross braces may be ordered at any time to add to your existing system. Different sized arms may be interchanged on racks to further tailor your racks to different uses. Standard and Heavy Duty arms (page 28) are designed for use on Series 3000, Series 4000 and Series 5000 uprights only. Series 1000 and Series 2000 components are not interchangeable with any other rack series.

Single sided uprights can be converted to doubles when used with longer bases designed to accommodate placement of arms on both sides. Upright capacities can be computed by multiplying the number of arms per upright by the individual arm capacities—NOT TO EXCEED TOTAL UPRIGHT CAPACITIES LISTED. Arm capacity is based on EVEN DISTRIBUTION OF LOAD. All racks are designed for quick assembly and come with complete instructions and hardware for installation.

Completely adjustable MECO OMAHA CANTILEVER RACKS eliminate storage problems. Heavy duty steel construction permits storage of tubes, bars, structurals and other long heavy items that must be kept off the floor. Bases can be used for extra storage. Forklift easily loads off and on arms and bases. Fast, convenient handling of heavy, long unwieldy stock. Instant accessibility to one piece or a full load. For longer materials, simply add braces and uprights to fit your requirements.

Specially designed MECO OMAHA CANTILEVER RACK systems may be required to meet your needs. MECO OMAHA representatives will work with you to develop the most feasible and economical rack system for your special situation. Special label requirements can be met at an additional cost. Ask us to quote prices and specifications for rack systems not covered in the MECO OMAHA BUYER'S GUIDE.

DETAILED SPECIFICATIONS ARE SET FORTH ON THE FOLLOWING PAGES

DESCRIPTION	UPRIGHT HEIGHTS	PAGE NO.
Series 1000 Medium Duty	6', 7', 8', 10', 12'	24
Series 2000 Medium-Heavy Duty	8', 10', 12', 14', 16', 18', 20'	25
Series 3000 Heavy Duty	8', 10', 12', 14', 15', 16', 18', 20'	26
Series 4000 Standard Heavy Duty	8', 10', 12', 14', 15', 16', 18', 20'	27
Series 5000 Extra Heavy Duty	12', 14', 15', 16', 18', 20'	28
Series 1000 Starter and Add-on Units	6', 8', 10'	29
Series 4000 Starter and Add-on Units	8', 10', 12'	29

Standard color for all cantilever rack components is gray. Custom colors available at additional cost.



WHAT IS CANTILEVER RACK?

Cantilever Rack is a freestanding storage unit with horizontal load carrying arms extending outward from a single vertical column. The absence of a vertical support on the outboard ends of the arms permits uninterrupted storage of long lengths of material.

Cantilever Rack is the **ideal system for storing furniture, steel bars, pipe and tubing, lumber and other long, heavy items** that must be kept off the floor...provides instant accessibility to one piece or a full load. Forklift easily loads off and on arms and bases. Being modular in nature, additional arms, uprights and braces may be added as storage requirements change.

Cantilever Rack is comprised of three components:

- Uprights
- Arms
- Brace Sets

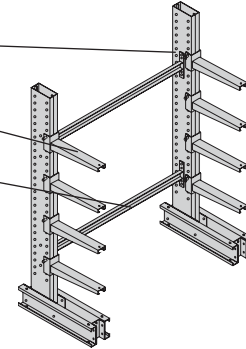

These components must be ordered in the appropriate quantities and capacities.

UPRIGHTS

Uprights consist of a vertical column and a horizontal base which is bolted to the column. A minimum of two uprights must be ordered to form a storage bay. Each edge of the column is punched vertically on 3" centers so it may be used as

a single or double sided upright depending on the size of base used. **NOTE:** The arms must never be placed on the back side of a single sided upright and base. Standard upright and base color is gray.

Single Sided Upright

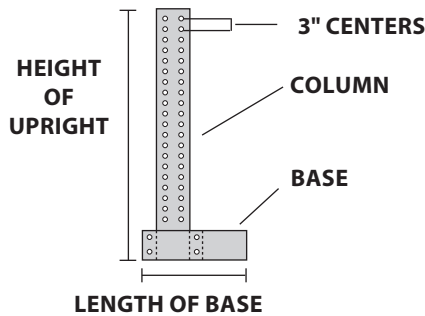

Holes are provided in the base to anchor the upright to the floor. Uprights must never be attached to walls, columns or other structures.

Double Sided Upright

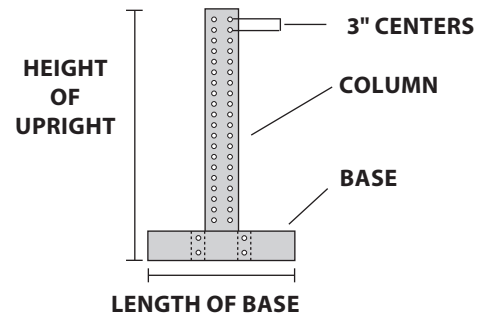

ARMS

Cantilever Arms are the heart of the rack system. Proper selection can make or break a successful storage plan. **MECO OMAHA** offers straight arms (generally used for storing stable loads such as lumber, steel sheets, cartons and skids) and inclined arms (for cylindrical objects or loads that tend to roll forward). Arms can be adjusted

on 3" centers up and down the upright and are available in lengths to 60" in a variety of capacities. The hair pin keeper permits instant adjustability and is easily inserted and removed for adjustment of arm height. Lips are available on all **MECO OMAHA** arms. Standard arm color is gray.

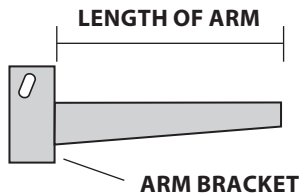

Straight Arm

Straight arms up to 48" long have a minimum pitch of 3/8" per foot to compensate for deflection. 54" and 60" arms have a minimum pitch of 5/8" per foot.

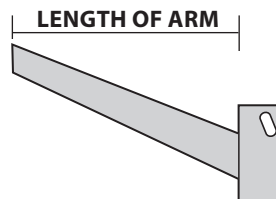

Inclined Arm

Inclined arms have a pitch of 20° or approximately 4.36" per foot.



MECO OMAHA
Hair Pin Keeper



BRACE SETS

Braces are structural channel members that are bolted between pairs of uprights to provide lateral stability to the rack system. X-bracing is utilized to increase the lateral stability of the taller (15' to 20') uprights. Brace

lengths are measured from centerline of upright to centerline of the next upright and are sold in sets rather than individual pieces. Standard brace color is gray.

Standard MECO OMAHA Brace Patterns

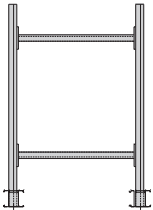

"2B" Horizontal Brace Pattern
Used on 6' to 10' Series 1000 uprights and 8' Series 2000, Series 3000 and Series 4000 uprights.

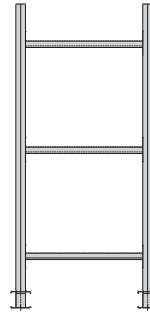

"3B" Horizontal Brace Pattern
Used on 12' Series 1000 uprights, 10' to 14' Series 2000, Series 3000 and Series 4000 uprights and 12' to 14' Series 5000 uprights.

"4BX" Horizontal Brace Pattern
Used on 16' to 20' Series 2000 uprights, 15' to 20' Series 3000, Series 4000 and Series 5000 uprights and all structural cantilever rack.

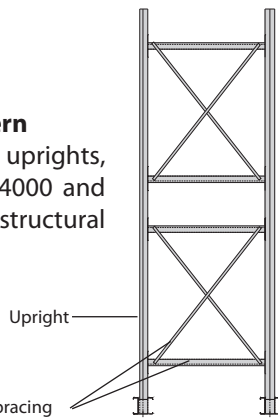

"4BXX" Horizontal Brace Pattern
Used on all 15' to 20' uprights when the brace length exceeds 84" centerline to centerline of upright.

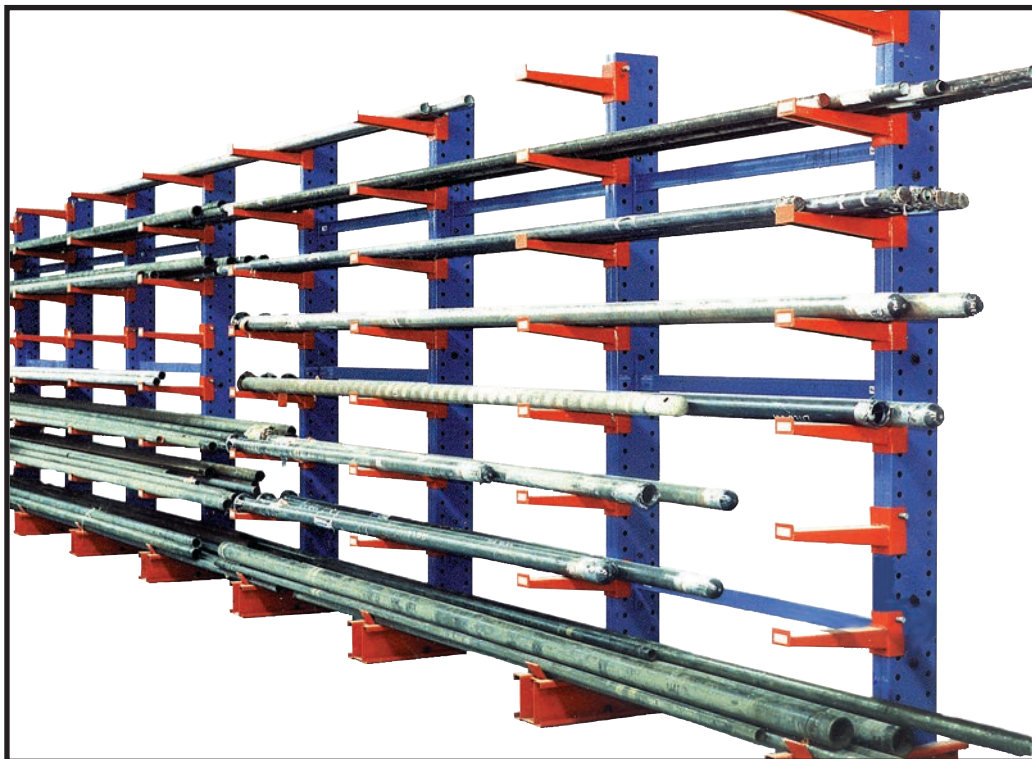
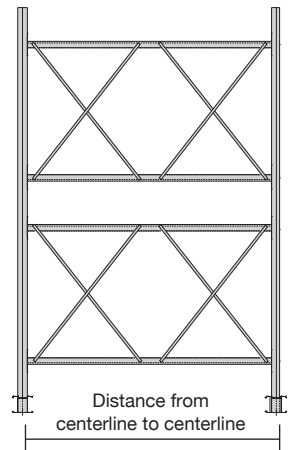

MECO OMAHA cantilever rack application consisting of uprights, arms and braces.

Standard color for all cantilever rack components is gray. Custom colors available at additional cost.



DESIGNING A CANTILEVER RACK SYSTEM

The key to a successful cantilever rack system is the answer to one question: **What is the product (load) being stored?** The answer must include the **length, depth, height** and

weight of the product. Once this data is ascertained it becomes a simple matter to determine the required arms, uprights and braces.

A. DETERMINE THE NUMBER AND SPACING OF ARMS

The load must be supported by enough arms to prevent load deflection. Deflection may cause damage to the load being stored as well as the arms (figure A1). To detect deflection, place the load over two wooden blocks (to represent cantilever arms) as shown in figure A2. If deflection is not present it is acceptable to use a two arm system as long as this does not create an overload

condition. If the load shows deflection use three blocks as shown in figure A3 or four blocks as in figure A4.

IMPORTANT: The load should overhang the end arms by one-half the distance from upright centerline to upright centerline. Failure to observe this measure may cause an overload condition on the arms.

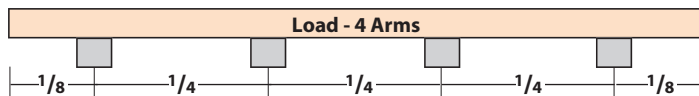
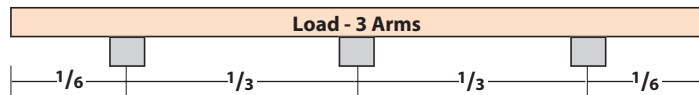
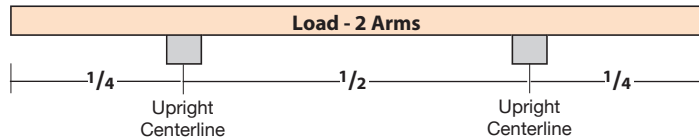
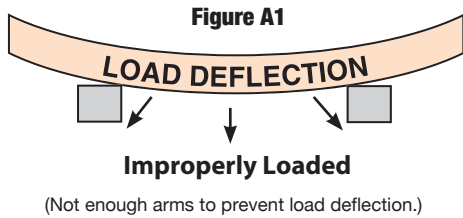

Figure A2

Figure A3

Figure A4

Adhering to these guidelines will ensure that each arm supports an equal amount of the load's weight.

B. DETERMINE THE LENGTH OF THE ARMS

The depth of the load should never exceed the length of the arm. A 48" wide bundle of plywood requires a 48" long arm, bundles of steel 24" wide require a 24" arm and so on. Rated

arm capacities may be seriously diminished if proper loading techniques are not observed. Figures B1, B2 and B3 illustrate correct and incorrect arm loading.

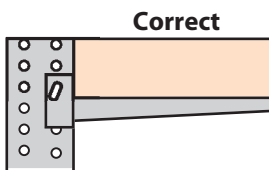

Figure B1

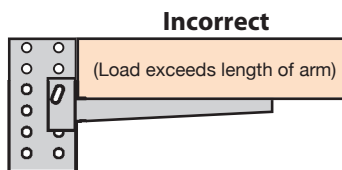

Figure B2

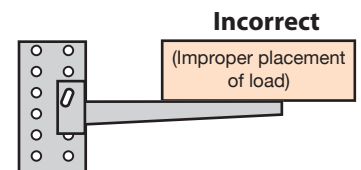

Figure B3

NOTE: All arm capacities are based on an evenly distributed load as in figures B4 and B5 below.

Evenly Distributed Load (front to back)
Full rated arm capacity

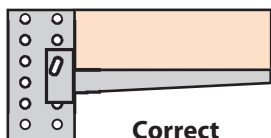

Figure B4

Centered Load
Full rated arm capacity

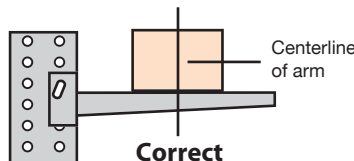

Figure B5

Tip Loading
Arm capacity may be reduced by up to 50%

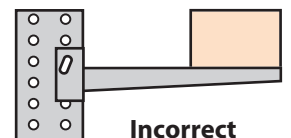

Figure B6



C. DETERMINE THE HEIGHT OF THE UPRIGHT

When determining the height of the upright it is important to consider the ceiling height, forklift reach, sprinkler systems and other factors, such as local building codes that might affect the overall height.

The height of the upright in figure C1 is determined by adding the base height, the number of loads to be stored, the arm thickness plus 6" clearance between the load and next arm. Contact your **MECO OMAHA** sales professional for various rack dimensions such as base height and arm thickness.

IMPORTANT: The load placed on the base does not diminish the rated capacity of the upright. Thus, the heaviest loads should be placed on the base.

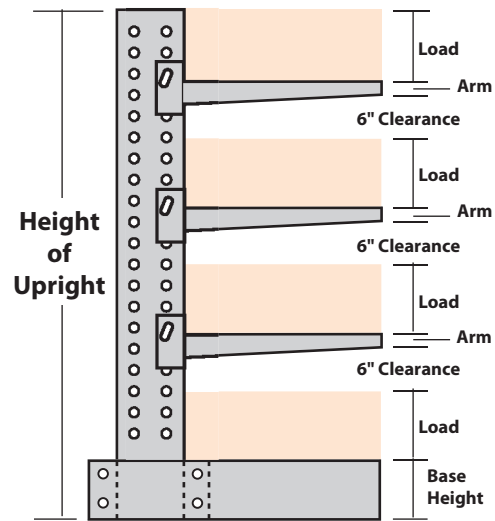

Figure C1

D. DETERMINE ARM AND UPRIGHT CAPACITIES

As previously discussed, each arm supports an equal amount of the load's weight. By determining the number of arms per level and dividing it into the weight per level, the required arm capacity can be determined (see example at right).

To determine the required capacity of each upright, multiply the number of arms per side by the load on each arm. In figure D1, each arm holds 2500 lbs. Twelve arms per side times 2500 lbs. per arm equals 30,000 lbs., which when divided by three uprights, results in a required minimum capacity of 10,000 lbs. per upright.

The correct upright can be selected by matching the minimum upright capacity of 10,000 lbs. with the upright capacities set forth on the following pages. Assuming a 48" arm, the U1061-NS on page 26 with 10,200 lbs. capacity and the U1061 on page 27 with 12,600 lbs. capacity are the only uprights that will handle the load. **NOTE:** The Series 1000 MU1057 has only 3100 lbs. capacity while the Series 2000 2U1062 has 8600 lbs. capacity.

The proper 48" arm (requiring 2500 lbs. of capacity) can be found on page 28: either the XHDSA48 at 2500 lbs. or the XHDSA483M at 3000 lbs. capacity.

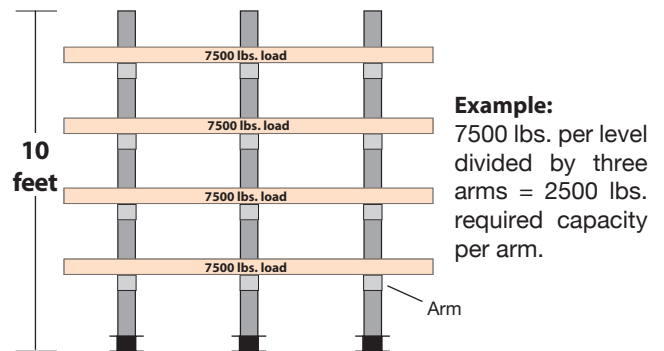

Figure D1

NOTE: Total arm capacity must never exceed total upright capacity.

E. DETERMINE BRACE LENGTH

Brace length is defined as the horizontal distance from centerline of upright to centerline of the next upright. Refer

to the various brace set charts for the brace length that most closely matches the arm spacing determined in step A.

The following pages set forth MECO OMAHA's wide range of cantilever racks – beginning with the Series 1000 Medium Duty on page 24 through the Series 5000 Extra Heavy Duty on page 28. MECO OMAHA representatives will work with you to develop the most feasible and economical rack system for your unique situation.



SERIES 1000 MEDIUM DUTY CANTILEVER RACK

EXCELLENT LOW COST STORAGE SYSTEM • IDEAL FOR MAINTENANCE DEPARTMENTS AND TOOL ROOMS

High quality **MECO OMAHA** Series 1000 Cantilever Rack is designed for use where heavier capacities are not required. This rack is similar to our popular heavier duty racks except for the use of lighter gauge steel and smaller dimensions of component parts. Available in 6', 7', 8', 10' and 12' single and double sided uprights with a choice of eight standard brace lengths (measured on center) to accommodate 12", 18", 24", 30", 36", 42" and 48" straight or inclined arms. Arms are completely adjustable on 3" centers up and down the full length of the uprights. Two or more uprights can be assembled into a continuous system.

This sturdy and stable rack is as convenient and versatile as the heavier duty racks but priced lower to reflect the reduced capacity. Installation is quick and easy. Racks can be tailored to your individual requirements. Uprights facilitate manual loading and unloading. Open base design affords easy forklift accessibility. Ideal for storing bar stock, pipe, tubing, lumber and many lightweight or hard-to-stock items that must be kept off the floor.



- EASY LOADING AND UNLOADING
- EVERY ITEM READILY AVAILABLE
- ALL WEIGHTS INCLUDE HARDWARE

MECO OMAHA SERIES 1000 UPRIGHTS, ARMS and BRACE SETS are not interchangeable with any other rack series.

SINGLE SIDED UPRIGHTS					
HEIGHT OF UPRIGHT	LENGTH OF BASE	LENGTH OF ARM	WEIGHT (LBS)	CAPACITY (LBS)	MODEL NO.
6'	33"	12" & 18"	82	8,100 & 6,600	MU633
	33"	24"	82	5,500	MU633
	45"	30"	90	4,700	MU645
	45"	36"	90	4,100	MU645
	57"	42" & 48"	100	3,700 & 3,300	MU657
7'	33"	12" & 18"	89	7,900 & 6,400	MU733
	33"	24"	89	5,300	MU733
	45"	30"	97	4,600	MU745
	45"	36"	97	4,100	MU745
	57"	42" & 48"	107	3,700 & 3,300	MU757
8'	33"	12" & 18"	96	7,600 & 6,300	MU833
	33"	24"	96	5,300	MU833
	45"	30"	104	4,500	MU845
	45"	36"	104	4,000	MU845
	57"	42" & 48"	114	3,600 & 3,200	MU857
10'	33"	12" & 18"	110	7,100 & 5,900	MU1033
	33"	24"	110	5,000	MU1033
	45"	30"	118	4,400	MU1045
	45"	36"	118	3,800	MU1045
	57"	42" & 48"	128	3,400 & 3,100	MU1057
12'	33"	12" & 18"	124	6,500 & 5,400	MU1233
	33"	24"	124	4,700	MU1233
	45"	30"	132	4,100	MU1245
	45"	36"	132	3,700	MU1245
	57"	42" & 48"	142	3,300 & 3,000	MU1257

DOUBLE SIDED UPRIGHTS					
HEIGHT OF UPRIGHT	LENGTH OF BASE	LENGTH OF ARM	WEIGHT (LBS)	CAPACITY (LBS)	MODEL NO.
6'	54"	12" & 18"	99	16,200 & 13,200	MDU654
	54"	24"	99	11,000	MDU654
	78"	30"	115	9,400	MDU678
	78"	36"	115	8,200	MDU678
	102"	42" & 48"	135	7,400 & 6,600	MDU6102
7'	54"	12" & 18"	106	15,800 & 12,800	MDU754
	54"	24"	106	10,600	MDU754
	78"	30"	122	9,200	MDU778
	78"	36"	122	8,200	MDU778
	102"	42" & 48"	142	7,400 & 6,600	MDU7102
8'	54"	12" & 18"	113	15,200 & 12,600	MDU854
	54"	24"	113	10,600	MDU854
	78"	30"	129	9,000	MDU878
	78"	36"	129	8,000	MDU878
	102"	42" & 48"	149	7,200 & 6,400	MDU8102
10'	54"	12" & 18"	127	14,200 & 11,800	MDU1054
	54"	24"	127	10,000	MDU1054
	78"	30"	143	8,800	MDU1078
	78"	36"	143	7,600	MDU1078
	102"	42" & 48"	163	6,800 & 6,200	MDU10102
12'	54"	12" & 18"	141	13,000 & 10,800	MDU1254
	54"	24"	141	9,400	MDU1254
	78"	30"	157	8,200	MDU1278
	78"	36"	157	7,400	MDU1278
	102"	42" & 48"	177	6,600 & 6,000	MDU12102

STRAIGHT ARMS				
LENGTH	CAPACITY	WEIGHT	MODEL NO. WITHOUT LIP	MODEL NO. WITH LIP
12"	1000 lbs	6 lbs	MSA12	MSA12L
18"	750 lbs	7 lbs	MSA18	MSA18L
24"	600 lbs	8 lbs	MSA24	MSA24L
30"	500 lbs	9 lbs	MSA30	MSA30L
36"	400 lbs	10 lbs	MSA36	MSA36L
42"	350 lbs	13 lbs	MSA42	MSA42L
48"	300 lbs	15 lbs	MSA48	MSA48L

INCLINED ARMS				
LENGTH	CAPACITY	WEIGHT	MODEL NO. WITHOUT LIP	MODEL NO. WITH LIP
12"	1000 lbs	6 lbs	MIA12	MIA12L
18"	750 lbs	7 lbs	MIA18	MIA18L
24"	600 lbs	8 lbs	MIA24	MIA24L
30"	500 lbs	9 lbs	MIA30	MIA30L
36"	400 lbs	10 lbs	MIA36	MIA36L
42"	350 lbs	13 lbs	MIA42	MIA42L
48"	300 lbs	15 lbs	MIA48	MIA48L

STRAIGHT ARMS have a minimum pitch of 3/8" per foot to compensate for deflection. Arm capacities are based on an evenly distributed load.

INCLINED ARMS have a pitch of 20 degrees or approximately 4.36" per foot. Arm capacities are based on an evenly distributed load.

NOTE: Arm lips are not intended to bear any portion of the load.

LENGTH*	BRACES FOR 6' - 10' UPRIGHTS - SET OF TWO		BRACES FOR 12' UPRIGHTS - SET OF THREE	
	MODEL NO.	WEIGHT	MODEL NO.	WEIGHT
23"	M2B24	21 lbs	M3B24	31 lbs
35"	M2B36	28 lbs	M3B36	41 lbs
41"	M2B42	31 lbs	M3B42	47 lbs
47"	M2B48	35 lbs	M3B48	52 lbs
59"	M2B60	42 lbs	M3B60	62 lbs
71"	M2B72	49 lbs	M3B72	73 lbs
83"	M2B84	56 lbs	M3B84	83 lbs
95"	M2B96	63 lbs	M3B96	94 lbs

* Length of braces is measured from center of upright to center of upright.



SERIES 2000 MEDIUM-HEAVY DUTY CANTILEVER RACK

MECO OMAHA SERIES 2000 UPRIGHTS, ARMS and BRACE SETS are not interchangeable with any other rack series.

SINGLE SIDED UPRIGHTS					
HEIGHT OF UPRIGHT	LENGTH OF BASE	LENGTH OF ARM	WEIGHT (LBS)	CAPACITY (LBS)	MODEL NO.
8'	38"	12" & 18"	188	18,100 & 15,300	2U838
	38"	24"	188	13,300	2U838
	50"	30" & 36"	201	11,800 & 10,600	2U850
	62"	42" & 48"	215	9,600 & 8,800	2U862
10'	38"	12" & 18"	217	17,400 & 14,900	2U1038
	38"	24"	217	13,100	2U1038
	50"	30" & 36"	230	11,500 & 10,300	2U1050
	62"	42" & 48"	244	9,400 & 8,600	2U1062
12'	38"	12" & 18"	245	16,800 & 14,500	2U1238
	38"	24"	245	12,600	2U1238
	50"	30" & 36"	258	11,200 & 10,200	2U1250
	62"	42" & 48"	272	9,300 & 8,500	2U1262
14'	38"	12" & 18"	272	16,200 & 14,100	2U1438
	38"	24"	272	12,300	2U1438
	50"	30" & 36"	285	10,900 & 9,800	2U1450
	62"	42" & 48"	299	8,900 & 8,300	2U1462
16'	38"	12" & 18"	299	15,800 & 13,800	2U1638
	38"	24"	299	12,100	2U1638
	50"	30" & 36"	312	10,600 & 9,400	2U1650
	62"	42" & 48"	326	8,400 & 7,500	2U1662
18'	38"	12" & 18"	326	15,700 & 13,700	2U1838
	38"	24"	326	11,900	2U1838
	50"	30" & 36"	339	10,400 & 9,200	2U1850
	62"	42" & 48"	353	8,200 & 7,400	2U1862
20'	38"	12" & 18"	353	15,600 & 13,600	2U2038
	38"	24"	353	11,700	2U2038
	50"	30" & 36"	366	10,200 & 9,000	2U2050
	62"	42" & 48"	380	8,100 & 7,300	2U2062

DOUBLE SIDED UPRIGHTS					
HEIGHT OF UPRIGHT	LENGTH OF BASE	LENGTH OF ARM	WEIGHT (LBS)	CAPACITY (LBS)	MODEL NO.
8'	59"	12" & 18"	216	36,200 & 30,600	2DU859
	59"	24"	216	26,600	2DU859
	83"	30" & 36"	243	23,600 & 21,200	2DU883
	107"	42" & 48"	270	19,200 & 17,600	2DU8107
10'	59"	12" & 18"	245	34,800 & 29,800	2DU1059
	59"	24"	245	26,200	2DU1059
	83"	30" & 36"	272	23,000 & 20,600	2DU1083
	107"	42" & 48"	299	18,800 & 17,200	2DU10107
12'	59"	12" & 18"	273	33,600 & 29,000	2DU1259
	59"	24"	273	25,200	2DU1259
	83"	30" & 36"	300	22,400 & 20,400	2DU1283
	107"	42" & 48"	327	18,600 & 17,000	2DU12107
14'	59"	12" & 18"	300	32,400 & 28,200	2DU1459
	59"	24"	300	24,600	2DU1459
	83"	30" & 36"	327	21,800 & 19,600	2DU1483
	107"	42" & 48"	354	17,800 & 16,600	2DU14107
16'	59"	12" & 18"	327	31,600 & 27,600	2DU1659
	59"	24"	327	24,200	2DU1659
	83"	30" & 36"	354	21,200 & 18,800	2DU1683
	107"	42" & 48"	381	16,800 & 15,000	2DU16107
18'	59"	12" & 18"	354	31,400 & 27,400	2DU1859
	59"	24"	354	23,800	2DU1859
	83"	30" & 36"	381	20,800 & 18,400	2DU1883
	107"	42" & 48"	408	16,400 & 14,800	2DU18107
20'	59"	12" & 18"	381	31,200 & 27,200	2DU2059
	59"	24"	381	23,400	2DU2059
	83"	30" & 36"	408	20,400 & 18,000	2DU2083
	107"	42" & 48"	435	16,200 & 14,600	2DU20107

STRAIGHT ARMS				
LENGTH	CAPACITY	WEIGHT	MODEL NO. WITHOUT LIP	MODEL NO. WITH LIP
12"	2000 lbs	7 lbs	2SA12	2SA12L
18"	1500 lbs	8 lbs	2SA18	2SA18L
24"	1200 lbs	9 lbs	2SA24	2SA24L
30"	1000 lbs	10 lbs	2SA30	2SA30L
36"	800 lbs	11 lbs	2SA36	2SA36L
42"	700 lbs	14 lbs	2SA42	2SA42L
48"	600 lbs	16 lbs	2SA48	2SA48L

INCLINED ARMS				
LENGTH	CAPACITY	WEIGHT	MODEL NO. WITHOUT LIP	MODEL NO. WITH LIP
12"	2000 lbs	7 lbs	2IA12	2IA12L
18"	1500 lbs	8 lbs	2IA18	2IA18L
24"	1200 lbs	9 lbs	2IA24	2IA24L
30"	1000 lbs	10 lbs	2IA30	2IA30L
36"	800 lbs	11 lbs	2IA36	2IA36L
42"	700 lbs	14 lbs	2IA42	2IA42L
48"	600 lbs	16 lbs	2IA48	2IA48L

STRAIGHT ARMS have a minimum pitch of 3/8" per foot to compensate for deflection. Arm capacities are based on an evenly distributed load.

INCLINED ARMS have a pitch of 20 degrees or approximately 4.36" per foot. Arm capacities are based on an evenly distributed load.

Note that arm lips are not intended to bear any portion of the load.



Single Sided Uprights

HEAVY DUTY AND EXTRA HEAVY DUTY STRAIGHT ARMS				
LENGTH	CAPACITY	WEIGHT	MODEL NO. WITHOUT LIP	MODEL NO. WITH LIP
24"	2400 lbs	14 lbs	2HDSA24	2HDSA24L
30"	2000 lbs	16 lbs	2HDSA30	2HDSA30L
36"	1500 lbs	18 lbs	2HDSA36	2HDSA36L
	2400 lbs	23 lbs	2XHDSA36	2XHDSA36L
42"	1400 lbs	20 lbs	2HDSA42	2HDSA42L
	2400 lbs	26 lbs	2XHDSA42	2XHDSA42L
48"	1000 lbs	21 lbs	2HDSA481M	2HDSA48L1M
	1500 lbs	24 lbs	2HDSA48	2HDSA48L
	2000 lbs	29 lbs	2XHDSA48	2XHDSA48L



Double Sided Uprights

LENGTH*	BRACES FOR 8' UPRIGHTS – SET OF TWO		BRACES FOR 10' - 14' UPRIGHTS – SET OF THREE		BRACES FOR 16' - 20' UPRIGHTS – SET OF FOUR INCLUDING X-BRACING	
	MODEL NO.	WEIGHT	MODEL NO.	WEIGHT	MODEL NO.	WEIGHT
23"	22B24	21 lbs	23B24	31 lbs	24B24X	66 lbs
35"	22B36	28 lbs	23B36	41 lbs	24B36X	81 lbs
41"	22B42	31 lbs	23B42	47 lbs	24B42X	90 lbs
47"	22B48	35 lbs	23B48	52 lbs	24B48X	97 lbs
59"	22B60	42 lbs	23B60	62 lbs	24B60X	113 lbs
71"	22B72	49 lbs	23B72	73 lbs	24B72X	130 lbs
83"	22B84	56 lbs	23B84	83 lbs	24B84X	147 lbs
95"	22B96	63 lbs	23B96	94 lbs	24B96XX	182 lbs
119"	22B120	113 lbs	23B120	170 lbs	24B120XX	283 lbs

* Length of braces is measured from center of upright to center of upright.

ALL WEIGHTS INCLUDE HARDWARE



MODERN EQUIPMENT COMPANY, INC.

OMAHA

SERIES 3000 HEAVY DUTY CANTILEVER RACK

UPRIGHTS

FOR YOUR NORMAL INDUSTRIAL STORAGE REQUIREMENTS

SINGLE SIDED UPRIGHTS						DOUBLE SIDED UPRIGHTS					
HEIGHT OF UPRIGHT	LENGTH OF BASE	LENGTH OF ARM	WEIGHT (LBS)	CAPACITY (LBS)	MODEL NO.	HEIGHT OF UPRIGHT	LENGTH OF BASE	LENGTH OF ARM	WEIGHT (LBS)	CAPACITY (LBS)	MODEL NO.
8'	31"	12" & 18"	217	23,000 & 19,200	U831-NS	8'	53"	12" & 18"	253	46,000 & 38,400	DU853-NS
	37"	24"	225	16,500	U837-NS		65"	24"	270	33,000	DU865-NS
	49"	30"	243	14,400	U849-NS		82"	30"	295	28,800	DU882-NS
	49"	36"	243	12,800	U849-NS		82"	36"	295	25,600	DU882-NS
	61"	42"	261	11,500	U861-NS		106"	42"	329	23,000	DU8106-NS
	61"	48"	261	10,400	U861-NS		106"	48"	329	20,800	DU8106-NS
74"	54" & 60"	279	9,600 & 8,800	U874-NS	130"	54" & 60"	364	19,200 & 17,600	DU8130-NS		
10'	31"	12" & 18"	255	22,200 & 18,600	U1031-NS	10'	53"	12" & 18"	291	44,400 & 37,200	DU1053-NS
	37"	24"	263	16,100	U1037-NS		65"	24"	308	32,200	DU1065-NS
	49"	30"	281	14,100	U1049-NS		82"	30"	333	28,200	DU1082-NS
	49"	36"	281	12,500	U1049-NS		82"	36"	333	25,000	DU1082-NS
	61"	42"	299	11,300	U1061-NS		106"	42"	367	22,600	DU10106-NS
	61"	48"	299	10,200	U1061-NS		106"	48"	367	20,400	DU10106-NS
74"	54" & 60"	317	9,400 & 8,700	U1074-NS	130"	54" & 60"	402	18,800 & 17,400	DU10130-NS		
12'	31"	12" & 18"	291	21,300 & 18,000	U1231-NS	12'	53"	12" & 18"	327	42,600 & 36,000	DU1253-NS
	37"	24"	299	15,600	U1237-NS		65"	24"	344	31,200	DU1265-NS
	49"	30"	317	13,700	U1249-NS		82"	30"	369	27,400	DU1282-NS
	49"	36"	317	12,200	U1249-NS		82"	36"	369	24,400	DU1282-NS
	61"	42"	335	11,000	U1261-NS		106"	42"	403	22,000	DU12106-NS
	61"	48"	335	10,100	U1261-NS		106"	48"	403	20,200	DU12106-NS
74"	54" & 60"	353	9,200 & 8,600	U1274-NS	130"	54" & 60"	438	18,400 & 17,200	DU12130-NS		
14'	37"	12" & 18"	338	20,500 & 17,400	U1437-NS	14'	65"	12" & 18"	382	41,000 & 34,800	DU1465-NS
	37"	24"	338	15,100	U1437-NS		82"	24"	382	30,200	DU1465-NS
	49"	30"	356	13,300	U1449-NS		82"	30"	407	26,600	DU1482-NS
	49"	36"	356	11,800	U1449-NS		82"	36"	407	23,600	DU1482-NS
	61"	42"	373	10,700	U1461-NS		106"	42"	442	21,400	DU14106-NS
	61"	48"	373	9,800	U1461-NS		106"	48"	442	19,600	DU14106-NS
74"	54" & 60"	391	9,000 & 8,300	U1474-NS	130"	54" & 60"	476	18,000 & 16,600	DU14130-NS		
15'	37"	12" & 18"	358	20,000 & 17,100	U1537-NS	15'	65"	12" & 18"	402	40,000 & 34,200	DU1565-NS
	37"	24"	358	14,800	U1537-NS		82"	24"	402	29,600	DU1565-NS
	49"	30"	375	13,200	U1549-NS		82"	30"	427	26,400	DU1582-NS
	49"	36"	375	11,600	U1549-NS		82"	36"	427	23,200	DU1582-NS
	61"	42"	393	10,500	U1561-NS		106"	42"	462	21,000	DU15106-NS
	61"	48"	393	9,700	U1561-NS		106"	48"	462	19,400	DU15106-NS
74"	54" & 60"	411	8,900 & 8,300	U1574-NS	130"	54" & 60"	496	17,800 & 16,600	DU15130-NS		
16'	37"	12" & 18"	376	19,300 & 16,600	U1637-NS	16'	65"	12" & 18"	420	38,600 & 33,200	DU1665-NS
	37"	24"	376	14,400	U1637-NS		82"	24"	420	28,800	DU1665-NS
	49"	30"	393	12,800	U1649-NS		82"	30"	445	25,600	DU1682-NS
	49"	36"	393	11,300	U1649-NS		82"	36"	445	22,600	DU1682-NS
	61"	42"	411	10,400	U1661-NS		106"	42"	479	20,800	DU16106-NS
	61"	48"	411	9,500	U1661-NS		106"	48"	479	19,000	DU16106-NS
74"	54" & 60"	429	8,800 & 8,200	U1674-NS	130"	54" & 60"	514	17,600 & 16,400	DU16130-NS		
18'	49"	12" & 18"	429	18,200 & 15,600	U1849-NS	18'	82"	12" & 18"	480	36,400 & 31,200	DU1882-NS
	49"	24"	429	13,800	U1849-NS		82"	24"	480	27,600	DU1882-NS
	49"	30"	429	12,300	U1849-NS		82"	30"	480	24,600	DU1882-NS
	49"	36"	429	10,800	U1849-NS		82"	36"	480	21,600	DU1882-NS
	61"	42"	446	9,900	U1861-NS		106"	42"	515	19,800	DU18106-NS
	61"	48"	446	9,200	U1861-NS		106"	48"	515	18,400	DU18106-NS
74"	54" & 60"	464	8,500 & 8,000	U1874-NS	130"	54" & 60"	549	17,000 & 16,000	DU18130-NS		
20'	49"	12" & 18"	464	16,700 & 14,600	U2049-NS	20'	82"	12" & 18"	516	33,400 & 29,200	DU2082-NS
	49"	24"	464	12,900	U2049-NS		82"	24"	516	25,800	DU2082-NS
	49"	30"	464	11,700	U2049-NS		82"	30"	516	23,400	DU2082-NS
	49"	36"	464	10,400	U2049-NS		82"	36"	516	20,800	DU2082-NS
	61"	42"	481	9,400	U2061-NS		106"	42"	550	18,800	DU20106-NS
	61"	48"	481	8,800	U2061-NS		106"	48"	550	17,600	DU20106-NS
74"	54" & 60"	500	8,100 & 7,600	U2074-NS	130"	54" & 60"	584	16,200 & 15,200	DU20130-NS		

A MECO OMAHA rack system can be specifically designed to meet your individual requirements. MECO OMAHA representatives will work with you to develop the most feasible and economical rack system for your special situation.

BRACE SETS

All braces can be used on SERIES 3000, SERIES 4000 or SERIES 5000 uprights only.

LENGTH*	FOR 8' UPRIGHTS SET OF TWO		FOR 10' - 14' UPRIGHTS SET OF THREE		FOR 15' - 20' UPRIGHTS SET OF FOUR INCLUDING X-BRACING	
	MODEL NO.	WEIGHT	MODEL NO.	WEIGHT	MODEL NO.	WEIGHT
24"	2B24	21 lbs	3B24	31 lbs	4B24X	66 lbs
36"	2B36	28 lbs	3B36	41 lbs	4B36X	81 lbs
42"	2B42	31 lbs	3B42	47 lbs	4B42X	90 lbs
48"	2B48	35 lbs	3B48	52 lbs	4B48X	97 lbs
60"	2B60	42 lbs	3B60	62 lbs	4B60X	113 lbs
72"	2B72	49 lbs	3B72	73 lbs	4B72X	130 lbs
84"	2B84	56 lbs	3B84	83 lbs	4B84X	147 lbs
96"	2B96	63 lbs	3B96	94 lbs	4B96XX	182 lbs
120"	2B120	113 lbs	3B120	170 lbs	4B120XX	283 lbs

*Length of braces is measured from center of upright to center of upright.

ALL WEIGHTS INCLUDE HARDWARE





SERIES 4000 STANDARD HEAVY DUTY CANTILEVER RACK UPRIGHTS

FOR YOUR NORMAL HEAVY DUTY INDUSTRIAL STORAGE REQUIREMENTS

SINGLE SIDED UPRIGHTS						DOUBLE SIDED UPRIGHTS					
HEIGHT OF UPRIGHT	LENGTH OF BASE	LENGTH OF ARM	WEIGHT (LBS)	CAPACITY (LBS)	MODEL NO.	HEIGHT OF UPRIGHT	LENGTH OF BASE	LENGTH OF ARM	WEIGHT (LBS)	CAPACITY (LBS)	MODEL NO.
8'	31"	12" & 18"	237	28,600 & 24,700	U831	8'	53"	12" & 18"	273	57,200 & 49,400	DU853
	37"	24"	245	21,500	U837		65"	24"	290	43,000	DU865
	49"	30"	263	18,300	U849		82"	30"	315	36,600	DU882
	49"	36"	263	16,000	U849		82"	36"	315	32,000	DU882
	61"	42"	281	14,200	U861		106"	42"	349	28,400	DU8106
	61"	48"	281	12,800	U861		106"	48"	349	25,600	DU8106
	74"	54" & 60"	299	11,600 & 10,700	U874		130"	54" & 60"	384	23,200 & 21,400	DU8130
10'	31"	12" & 18"	275	28,500 & 24,600	U1031	10'	53"	12" & 18"	311	57,000 & 49,200	DU1053
	37"	24"	283	21,300	U1037		65"	24"	328	42,600	DU1065
	49"	30"	301	18,200	U1049		82"	30"	353	36,400	DU1082
	49"	36"	301	15,800	U1049		82"	36"	353	31,600	DU1082
	61"	42"	319	14,100	U1061		106"	42"	387	28,200	DU10106
	61"	48"	319	12,600	U1061		106"	48"	387	25,200	DU10106
	74"	54" & 60"	337	11,500 & 10,600	U1074		130"	54" & 60"	422	23,000 & 21,200	DU10130
12'	31"	12" & 18"	311	28,200 & 24,400	U1231	12'	53"	12" & 18"	347	56,400 & 48,800	DU1253
	37"	24"	319	20,900	U1237		65"	24"	364	41,800	DU1265
	49"	30"	337	17,800	U1249		82"	30"	389	35,600	DU1282
	49"	36"	337	15,600	U1249		82"	36"	389	31,200	DU1282
	61"	42"	355	13,900	U1261		106"	42"	423	27,800	DU12106
	61"	48"	355	12,500	U1261		106"	48"	423	25,000	DU12106
	74"	54" & 60"	373	11,400 & 10,500	U1274		130"	54" & 60"	458	22,800 & 21,000	DU12130
14'	37"	12" & 18"	358	27,400 & 23,400	U1437	14'	65"	12" & 18"	402	54,800 & 46,800	DU1465
	37"	24"	358	20,200	U1437		65"	24"	402	40,400	DU1465
	49"	30"	376	17,600	U1449		82"	30"	427	35,200	DU1482
	49"	36"	376	15,400	U1449		82"	36"	427	30,800	DU1482
	61"	42"	393	13,700	U1461		106"	42"	462	27,400	DU14106
	61"	48"	393	12,400	U1461		106"	48"	462	24,800	DU14106
	74"	54" & 60"	411	11,300 & 10,400	U1474		130"	54" & 60"	496	22,600 & 20,800	DU14130
15'	37"	12" & 18"	378	27,100 & 22,600	U1537	15'	65"	12" & 18"	422	54,200 & 45,200	DU1565
	37"	24"	378	19,200	U1537		65"	24"	422	38,400	DU1565
	49"	30"	395	16,900	U1549		82"	30"	447	33,800	DU1582
	49"	36"	395	15,000	U1549		82"	36"	447	30,000	DU1582
	61"	42"	413	13,600	U1561		106"	42"	482	27,200	DU15106
	61"	48"	413	12,300	U1561		106"	48"	482	24,600	DU15106
	74"	54" & 60"	431	11,200 & 10,300	U1574		130"	54" & 60"	516	22,400 & 20,600	DU15130
16'	37"	12" & 18"	396	23,700 & 20,300	U1637	16'	65"	12" & 18"	440	47,400 & 40,600	DU1665
	37"	24"	396	17,600	U1637		65"	24"	440	35,200	DU1665
	49"	30"	413	15,300	U1649		82"	30"	465	30,600	DU1682
	49"	36"	413	14,000	U1649		82"	36"	465	28,000	DU1682
	61"	42"	431	12,900	U1661		106"	42"	499	25,800	DU16106
	61"	48"	431	12,000	U1661		106"	48"	499	24,000	DU16106
	74"	54" & 60"	449	11,100 & 10,300	U1674		130"	54" & 60"	534	22,200 & 20,600	DU16130
18'	49"	12" & 18"	449	22,200 & 19,200	U1849	18'	82"	12" & 18"	500	44,400 & 38,400	DU1882
	49"	24"	449	16,700	U1849		82"	24"	500	33,400	DU1882
	49"	30"	449	14,700	U1849		82"	30"	500	29,400	DU1882
	49"	36"	449	13,600	U1849		82"	36"	500	27,200	DU1882
	61"	42"	466	12,700	U1861		106"	42"	535	25,400	DU18106
	61"	48"	466	11,900	U1861		106"	48"	535	23,800	DU18106
	74"	54" & 60"	484	11,000 & 10,000	U1874		130"	54" & 60"	569	22,000 & 20,000	DU18130
20'	49"	12" & 18"	484	20,600 & 17,800	U2049	20'	82"	12" & 18"	536	41,200 & 35,600	DU2082
	49"	24"	484	15,800	U2049		82"	24"	536	31,600	DU2082
	49"	30"	484	13,900	U2049		82"	30"	536	27,800	DU2082
	49"	36"	484	12,800	U2049		82"	36"	536	25,600	DU2082
	61"	42"	501	11,900	U2061		106"	42"	570	23,800	DU20106
	61"	48"	501	11,200	U2061		106"	48"	570	22,400	DU20106
	74"	54" & 60"	520	10,500 & 9,800	U2074		130"	54" & 60"	604	21,000 & 19,600	DU20130

A MECO OMAHA rack system can be specifically designed to meet your individual requirements. MECO OMAHA representatives will work with you to develop the most feasible and economical rack system for your special situation.

ARMS can be used on SERIES 3000, SERIES 4000 or SERIES 5000 uprights only. Capacities are based on an evenly distributed load. Note that arm lips are not intended to bear any portion of the load.

STANDARD STRAIGHT ARMS				
LENGTH	CAPACITY	WEIGHT	MODEL NO. WITHOUT LIP	MODEL NO. WITH LIP
12"	3000 lbs	9 lbs	SA12	SA12L
18"	2500 lbs	11 lbs	SA18	SA18L
24"	2000 lbs	13 lbs	SA24	SA24L
30"	1500 lbs	15 lbs	SA30	SA30L
36"	1200 lbs	17 lbs	SA36	SA36L
42"	1100 lbs	19 lbs	SA42	SA42L
48"	1000 lbs	21 lbs	SA48	SA48L
54"	800 lbs	24 lbs	SA54	SA54L
60"	600 lbs	26 lbs	SA60	SA60L

STRAIGHT ARMS through 48" long have a minimum pitch of 3/8" per foot to compensate for deflection. 54" and 60" arms have a minimum pitch of 5/8" per foot.

STANDARD INCLINED ARMS				
LENGTH	CAPACITY	WEIGHT	MODEL NO. WITHOUT LIP	MODEL NO. WITH LIP
12"	3000 lbs	9 lbs	IA12	IA12L
18"	2500 lbs	11 lbs	IA18	IA18L
24"	2000 lbs	13 lbs	IA24	IA24L
30"	1500 lbs	15 lbs	IA30	IA30L
36"	1200 lbs	17 lbs	IA36	IA36L
42"	1100 lbs	22 lbs	IA42	IA42L
48"	1000 lbs	23 lbs	IA48	IA48L

INCLINED ARMS have a pitch of 20 degrees or approximately 4.36" per foot.

ALL WEIGHTS INCLUDE HARDWARE

See page 28 for Heavy Duty and Extra Heavy Duty Straight Arms for use with uprights on pages 26 and 27.



SERIES 5000 EXTRA HEAVY DUTY CANTILEVER RACK

UPRIGHTS

FOR STORAGE REQUIREMENTS WHICH DEMAND HEAVIER CAPACITY RACKS

MECO OMAHA SERIES 5000 CANTILEVER RACK solves your extra heavy duty storage problems and easily handles your toughest storage requirements. Contact your MECO OMAHA representative for your special storage needs.

SINGLE SIDED UPRIGHTS					
HEIGHT OF UPRIGHT	LENGTH OF BASE	LENGTH OF ARM	WEIGHT (LBS)	CAPACITY (LBS)	MODEL NO.
12'	40"	24"	410	28,700	XU1240
	52"	30"	432	24,800	XU1252
	52"	36"	432	21,900	XU1252
	64"	42"	454	19,600	XU1264
	64"	48"	454	17,700	XU1264
	76"	54"	477	16,100	XU1276
	76"	60"	477	14,900	XU1276
14'	40"	24"	455	28,400	XU1440
	52"	30"	477	24,700	XU1452
	52"	36"	477	21,000	XU1452
	64"	42"	499	19,100	XU1464
	64"	48"	499	17,600	XU1464
	76"	54"	522	16,000	XU1476
	76"	60"	522	14,600	XU1476
15'	52"	24"	497	28,200	XU1552
	52"	30"	497	22,600	XU1552
	52"	36"	497	20,700	XU1552
	64"	42"	519	18,900	XU1564
	64"	48"	519	17,400	XU1564
	76"	54"	542	15,900	XU1576
	76"	60"	542	14,500	XU1576
16'	52"	24"	522	27,600	XU1652
	52"	30"	522	24,300	XU1652
	52"	36"	522	20,500	XU1652
	64"	42"	544	18,700	XU1664
	64"	48"	544	17,200	XU1664
	76"	54"	567	15,700	XU1676
	76"	60"	567	14,400	XU1676
18'	52"	24"	565	25,900	XU1852
	52"	30"	565	23,100	XU1852
	52"	36"	565	20,400	XU1852
	64"	42"	587	18,200	XU1864
	64"	48"	587	16,800	XU1864
	76"	54"	610	15,300	XU1876
	76"	60"	610	14,100	XU1876
20'	52"	24"	607	25,300	XU2052
	52"	30"	607	21,800	XU2052
	52"	36"	607	19,700	XU2052
	64"	42"	629	17,600	XU2064
	64"	48"	629	16,300	XU2064
	76"	54"	652	14,900	XU2076
	76"	60"	652	13,800	XU2076

DOUBLE SIDED UPRIGHTS					
HEIGHT OF UPRIGHT	LENGTH OF BASE	LENGTH OF ARM	WEIGHT (LBS)	CAPACITY (LBS)	MODEL NO.
12'	66"	24"	464	57,400	XDU1266
	84"	30"	498	49,600	XDU1284
	84"	36"	498	43,800	XDU1284
	108"	42"	542	39,200	XDU12108
	108"	48"	542	35,400	XDU12108
	132"	54"	586	32,200	XDU12132
	132"	60"	586	29,800	XDU12132
14'	66"	24"	509	56,800	XDU1466
	84"	30"	543	49,400	XDU1484
	84"	36"	543	42,000	XDU1484
	108"	42"	587	38,200	XDU14108
	108"	48"	587	35,200	XDU14108
	132"	54"	631	32,000	XDU14132
	132"	60"	631	29,200	XDU14132
15'	84"	24"	563	56,400	XDU1584
	84"	30"	563	45,200	XDU1584
	84"	36"	563	41,400	XDU1584
	108"	42"	607	37,800	XDU15108
	108"	48"	607	34,800	XDU15108
	132"	54"	651	31,800	XDU15132
	132"	60"	651	29,000	XDU15132
16'	84"	24"	588	55,200	XDU1684
	84"	30"	588	48,600	XDU1684
	84"	36"	588	41,000	XDU1684
	108"	42"	632	37,400	XDU16108
	108"	48"	632	34,400	XDU16108
	132"	54"	676	31,400	XDU16132
	132"	60"	676	28,800	XDU16132
18'	84"	24"	630	51,800	XDU1884
	84"	30"	630	46,200	XDU1884
	84"	36"	630	40,800	XDU1884
	108"	42"	674	36,400	XDU18108
	108"	48"	674	33,600	XDU18108
	132"	54"	719	30,600	XDU18132
	132"	60"	719	28,200	XDU18132
20'	84"	24"	673	50,600	XDU2084
	84"	30"	673	43,600	XDU2084
	84"	36"	673	39,400	XDU2084
	108"	42"	717	35,200	XDU20108
	108"	48"	717	32,600	XDU20108
	132"	54"	761	29,800	XDU20132
	132"	60"	761	27,600	XDU20132

ARMS can be used on SERIES 3000, SERIES 4000 or SERIES 5000 uprights only. Capacities are based on an evenly distributed load. Note that arm lips are not intended to bear any portion of the load.

HEAVY DUTY AND EXTRA HEAVY DUTY STRAIGHT ARMS				
LENGTH	CAPACITY	WEIGHT	MODEL NO. WITHOUT LIP	MODEL NO. WITH LIP
36"	2175 lbs	28 lbs	HDSA36	HDSA36L
	3400 lbs	34 lbs	XHDSA36	XHDSA36L
42"	1865 lbs	31 lbs	HDSA42	HDSA42L
	2900 lbs	37 lbs	XHDSA42	XHDSA42L
48"	1630 lbs	34 lbs	HDSA48	HDSA48L
	2000 lbs	36 lbs	HDSA482M	HDSA48L2M
	2500 lbs	40 lbs	XHDSA48	XHDSA48L
	3000 lbs	39 lbs	XHDSA483M	XHDSA48L3M
	4000 lbs	51 lbs	XHDSA484M	XHDSA48L4M
54"	1440 lbs	38 lbs	HDSA54	HDSA54L
	2000 lbs	44 lbs	XHDSA54	XHDSA54L
60"	1300 lbs	42 lbs	HDSA60	HDSA60L
	1650 lbs	46 lbs	XHDSA60	XHDSA60L
	2000 lbs	61 lbs	XHDSA602M	XHDSA60L2M

MAXIMUM STANDARD ARMS PER UPRIGHT (UPRIGHT CAPACITIES MUST BE OBSERVED)		
UPRIGHT	SINGLE UPRIGHT	DOUBLE UPRIGHT
8'	9	18
10'	12	24
12'	14	28
14'	17	34
15'	18	36
16'	20	40
18'	22	44
20'	24	48

ALL WEIGHTS INCLUDE HARDWARE

See pages 26 and 27 for Brace Sets, Standard Straight Arms and Standard Inclined Arms for use with Series 5000 uprights.



CANTILEVER RACK STARTER AND ADD-ON UNITS

A COMPLETE STORAGE SYSTEM DESIGNED WITH FLEXIBILITY AND SIMPLICITY IN MIND

MECO OMAHA has assembled the most popular Series 1000 and Series 4000 cantilever components to create Starter and Add-On units—take the guesswork out of selecting a rack system! Order a single or double sided starter unit consisting of 2 uprights, straight arms and braces to assemble a single bay storage unit.

Create a continuous rack system with add-on units which include 1 Series 1000 upright, straight arms and the appropriate brace set. Choose models in upright heights of 6', 8' or 10'. Series 4000 models are available in 8', 10' and 12' heights and easily handle lighter capacity requirements.

SERIES 1000 MEDIUM DUTY CANTILEVER RACK

STARTER UNITS <i>INCLUDES: 2 UPRIGHTS, STRAIGHT ARMS, 1 BRACE SET (47" BRACE SET FOR 6' AND 8' UPRIGHTS, 71" BRACE SET FOR 10' UPRIGHTS)</i>								ADD-ON UNITS <i>INCLUDES: 1 UPRIGHT, STRAIGHT ARMS, 1 BRACE SET (47" BRACE SET FOR 6' AND 8' UPRIGHTS, 71" BRACE SET FOR 10' UPRIGHTS)</i>			
MODEL NO.	UPRIGHT		BASE LENGTH (IN)	ARMS*			WEIGHT (LBS)	MODEL NO.	ARMS*		WEIGHT (LBS)
	HEIGHT (FT)	CAPACITY (LBS)		LENGTH (IN)	QUANTITY	CAPACITY (LBS)			LENGTH (IN)	QUANTITY	
SINGLE SIDED UNITS								SINGLE SIDED UNITS			
SM6	6	8,100	33	12	6	1,000	235	AM6	12	3	135
SM8	8	5,300	33	24	8	600	291	AM8	24	4	163
SM10	10	3,800	45	36	12	400	405	AM10	36	6	227
DOUBLE SIDED UNITS								DOUBLE SIDED UNITS			
SMD6	6	16,200	54	12	12	1,000	305	AMD6	12	6	170
SMD8	8	10,600	54	24	16	600	389	AMD8	24	8	212
SMD10	10	7,600	78	36	24	400	575	AMD10	36	12	312

*Add Suffix "L" to Model Number for Arms with Lips.

SERIES 4000 STANDARD HEAVY DUTY CANTILEVER RACK

STARTER UNITS <i>INCLUDES: 2 UPRIGHTS, STRAIGHT ARMS, 6' BRACE SET</i>								ADD-ON UNITS <i>INCLUDES: 1 UPRIGHT, STRAIGHT ARMS, 6' BRACE SET</i>			
MODEL NO.	UPRIGHT		BASE LENGTH (IN)	ARMS*			WEIGHT (LBS)	MODEL NO.	ARMS*		WEIGHT (LBS)
	HEIGHT (FT)	CAPACITY (LBS)		LENGTH (IN)	QUANTITY	CAPACITY (LBS)			LENGTH (IN)	QUANTITY	
SINGLE SIDED UNITS								SINGLE SIDED UNITS			
SU8	8	21,500	37	24	8	2,000	643	AU8	24	4	346
SU10	10	15,800	49	36	12	1,200	879	AU10	36	6	476
SU12	12	12,500	61	48	16	1,000	1,119	AU12	48	8	596
DOUBLE SIDED UNITS								DOUBLE SIDED UNITS			
SDU8	8	43,000	65	24	16	2,000	837	ADU8	24	8	443
SDU10	10	31,600	82	36	24	1,200	1,187	ADU10	36	12	630
SDU12	12	25,000	106	48	32	1,000	1,591	ADU12	48	16	832

* Add Suffix "L" to Model Number for Arms with Lips.

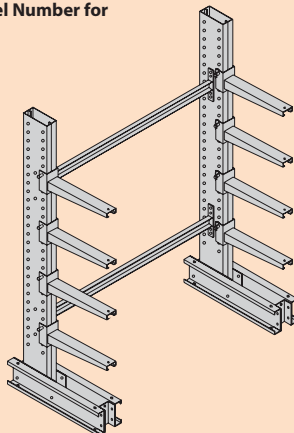

SU8
STARTER UNIT

AU8
ADD-ON UNIT

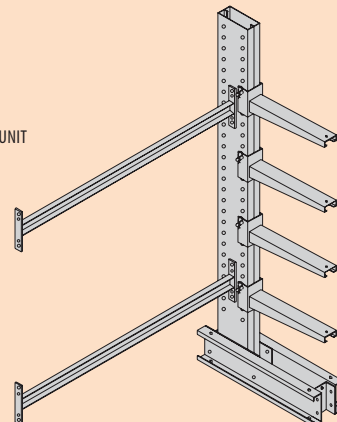



CANTILEVER RACK ACCESSORIES and HEAVYWEIGHT STRUCTURAL CANTILEVER RACK

Lip extends 2" above the arm surface

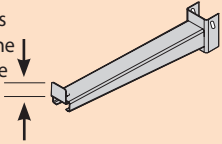

Bolt-On Arm Lips

All MECO OMAHA cantilever arms are factory punched to accept a bolt-on lip at any time. Lips can also be removed when they are no longer required. Lips are not intended to bear any portion of the load.

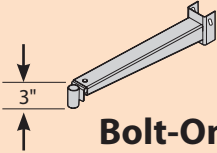

Bolt-On Pipe Sockets

Pipe sockets can be field installed or removed as needs dictate—just like bolt-on lips. Inside diameter of the socket is 1 3/8". Removable pipe is not included. Pipe sockets are not intended to bear any portion of the load.

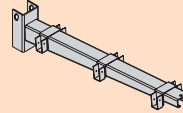

Drop-In Deck Support Saddles

Add a plywood deck to the cantilever system to store bulky items such as boxes, cartons and furniture. MECO OMAHA will pre-engineer the saddles to accommodate 2x4 cross supports. Saddles must be positioned along the arm to ensure equal distribution of weight. Deck support saddles can also be provided for the bases. Saddles must be fastened to the arms and bases. Field drilling is required. Fasteners are not included. Other saddle styles available. Please inquire.

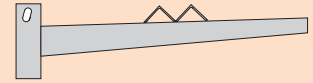

Welded Axle Cradles

Reels, spools and rolls can be stored between arms with the addition of axle cradles. Axle is not included.

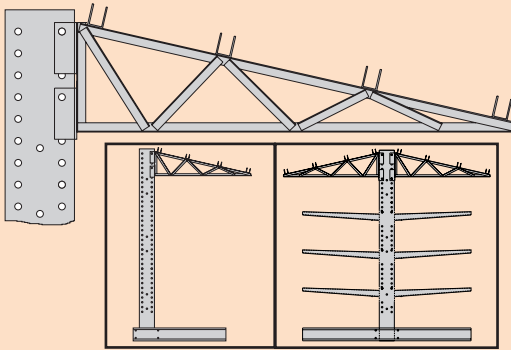

Single Sided Double Sided

Roof Supports

Turn a cantilever rack system into covered storage with MECO OMAHA roof supports. Can be used as single or double sided roof (depending on length of base used). Purlin clips included. **NOTE:** The use of roof supports can significantly reduce the rack's capacity due to wind and snow loads. MECO OMAHA will custom design the roof supports to conform with local wind and snow load conditions.

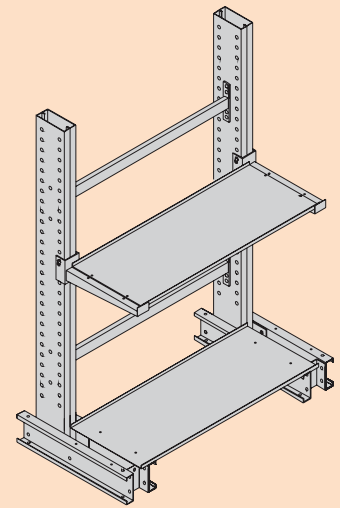

Steel Decks

MECO OMAHA offers optional steel decks to withstand the harshest industrial environment. Ideal for storage of short lengths of material, dies, castings and other items that require an uninterrupted length of heavy duty decking. Steel angles are welded to the underside of the deck for additional strength. Arms and decks are precision drilled to accept mounting hardware.

STRUCTURAL WIDE FLANGE UPRIGHTS

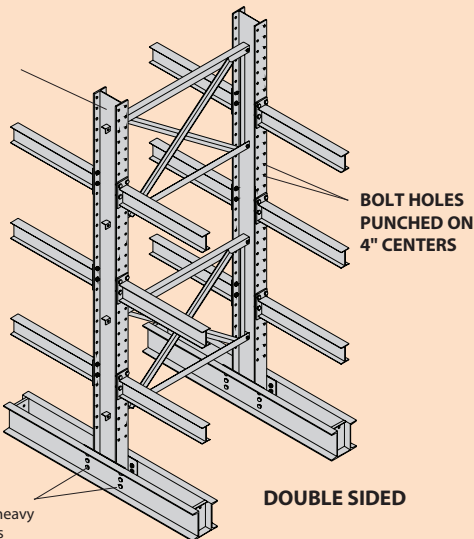

BOLT HOLES PUNCHED ON 4" CENTERS

STRUCTURAL BASE Attached to upright by heavy duty, high strength bolts

DOUBLE SIDED

Structural Cantilever Rack

Select a MECO OMAHA Structural Cantilever Rack system when your load requirements surpass normal capacities. Uprights are fabricated from rugged structural wide flange beams. Heights are available through 24 feet. Bolt holes are punched on 4" centers the full height of the upright. Both single sided and double sided uprights are available. Structural bases are attached to the uprights by heavy duty, high strength bolts. Load on bases does not affect the total upright capacity.



REEL RACKS

STORE AND DISPENSE VIRTUALLY ANY PRODUCT THAT MUST BE PAYED OUT FROM A REEL

MECO OMAHA's Reel Rack is built to withstand the abuse and punishment found in a manufacturing or distribution environment. Store and dispense poly or wire rope, hose, electrical cable or chain—anything on a reel or spool. Double welded uprights are manufactured from hefty 3" structural channel and welded to a 4" channel base. 96" units have 3 pair of axle brackets, 120" and 144" units have 4 pair (additional brackets may be ordered separately). The special MECO OMAHA axle bracket is adjustable on 2" centers up and down the uprights; brackets accept axle up to 2 1/2" diameter (not supplied by MECO OMAHA). It is strongly recommended that units be secured to the floor before use. Ships knocked down; gray enamel finish with orange axle brackets.

RR438
20,000 lb. capacity

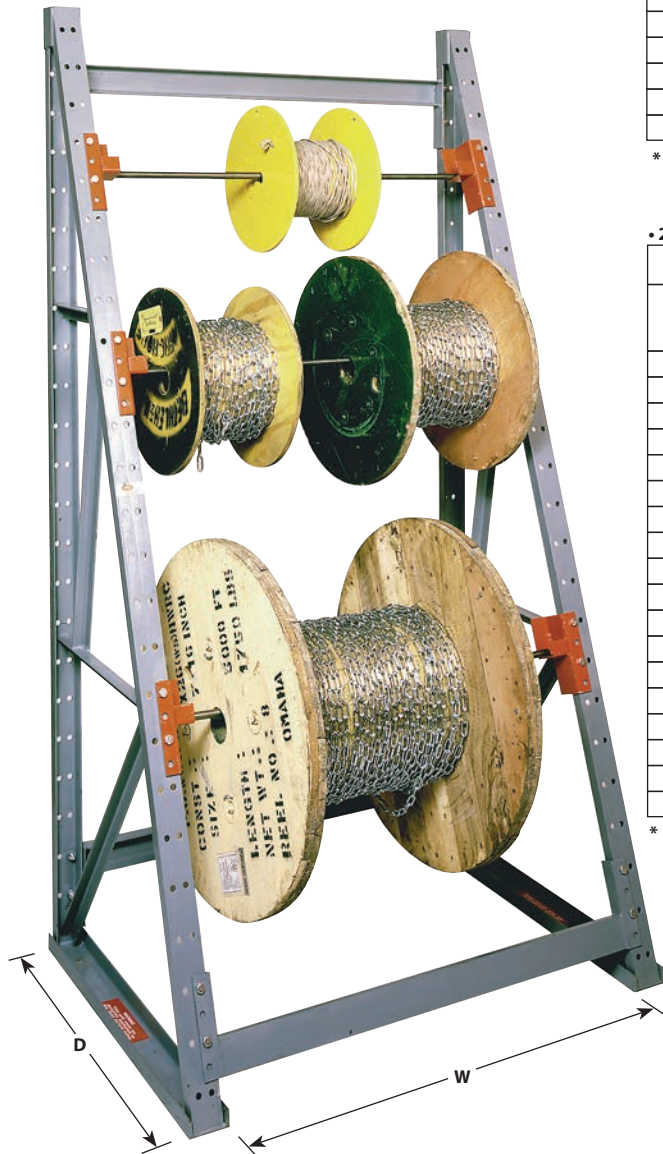

• 2000 LB CAPACITY PER LEVEL

STARTER UNITS					
MODEL NO.	DIMENSIONS*			MAX. REEL WIDTH	WEIGHT
	WIDTH	DEPTH	HEIGHT		
RR228	24"	24"	96"	19"	200 lbs
RR328	36"			31"	210 lbs
RR428	48"			43"	228 lbs
RR238	24"	36"		19"	216 lbs
RR338	36"			31"	226 lbs
RR438	48"			43"	244 lbs
RR2210	24"	24"	120"	19"	237 lbs
RR3210	36"			31"	247 lbs
RR4210	48"			43"	265 lbs
RR2310	24"	36"		19"	253 lbs
RR3310	36"			31"	263 lbs
RR4310	48"			43"	281 lbs
RR2212	24"	24"	144"	19"	296 lbs
RR3212	36"			31"	306 lbs
RR4212	48"			43"	324 lbs
RR2312	24"	36"		19"	312 lbs
RR3312	36"			31"	322 lbs
RR4312	48"			43"	340 lbs
RR-BKT	Axle Brackets (per pair)				6 lbs

* WIDTH FIGURE REPRESENTS THE INSIDE DIMENSION. ADD 8" TO WIDTH FIGURE FOR OVERALL WIDTH DIMENSION.

• 2000 LB CAPACITY PER LEVEL

ADD-ON UNITS					
MODEL NO.	DIMENSIONS*			MAX. REEL WIDTH	WEIGHT
	WIDTH	DEPTH	HEIGHT		
RR228-A	24"	24"	96"	19"	125 lbs
RR328-A	36"			31"	135 lbs
RR428-A	48"			43"	153 lbs
RR238-A	24"	36"		19"	133 lbs
RR338-A	36"			31"	143 lbs
RR438-A	48"			43"	161 lbs
RR2210-A	24"	24"	120"	19"	147 lbs
RR3210-A	36"			31"	157 lbs
RR4210-A	48"			43"	175 lbs
RR2310-A	24"	36"		19"	155 lbs
RR3310-A	36"			31"	165 lbs
RR4310-A	48"			43"	183 lbs
RR2212-A	24"	24"	144"	19"	176 lbs
RR3212-A	36"			31"	186 lbs
RR4212-A	48"			43"	204 lbs
RR2312-A	24"	36"		19"	184 lbs
RR3312-A	36"			31"	194 lbs
RR4312-A	48"			43"	212 lbs

* WIDTH FIGURE REPRESENTS THE INSIDE DIMENSION. OVERALL WIDTH WILL INCREASE BY 4" WHEN ADDED TO A STARTER UNIT.

**SEE PAGE 45
FOR ADDITIONAL
REEL HANDLING EQUIPMENT**



U-RACKS

MODULAR, LOW COST STORAGE OF BAR AND PIPE STOCK

MECO OMAHA solves your bar and pipe storage problems with our portable U-Racks. Totally adaptable to your space and storage requirements, these handy racks require virtually no set-up time and are easily handled by just one person. Stacking is easy with interlocking steel frames.

Each rack features double welded construction. Vary the load capacities by moving U-Racks closer together or further apart. Units may not be spaced more than 72" apart. Racks can be stacked up to 4 high: **maximum stacked capacity for the UR6 is 6,000 lbs. per column and 10,000 lbs. per column for the UR10.** Capacity per individual unit cannot exceed 3000 lbs. for the UR6 and 5000 lbs. for the UR10. Useable space of the UR6 when stacked increases from 16 1/2" at the base to 20 1/2" at the top; the UR10 increases from 16 1/2" at the base to 22 1/2" at the top. Clear height for both models is 15 3/4". Orange enamel finish.

• SHIPS IN A CARTON VIA UPS

MODEL NO.	STACKING CAPACITY	WEIGHT
UR6	6,000 lbs per column	23 lbs
UR10	10,000 lbs per column	27 lbs

NOTE: THE UR6 AND UR10 ARE NOT INTERSTACKABLE

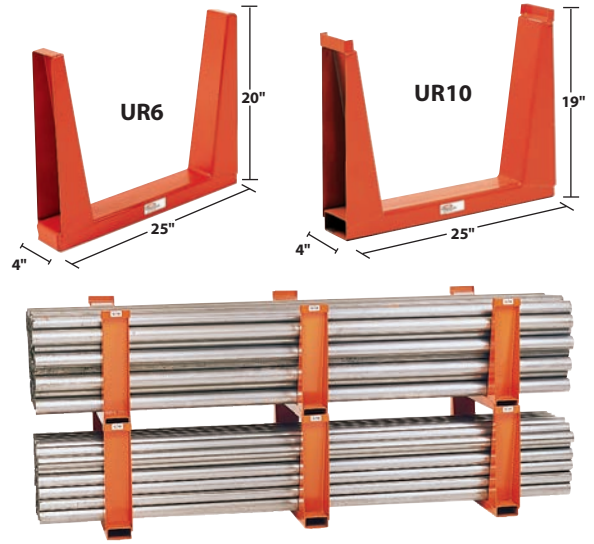

UR10 stacked two high using three columns

VERTICAL STORAGE RACKS

IDEAL FOR ON-EDGE STORAGE OF SHEET MATERIAL, PLATES AND PANELS

The Vertical Storage Rack by **MECO OMAHA** provides safe, convenient storage for your sheet material. Sheets up to 12' long and 6' wide may be stored allowing high visibility and easy retrieval. Provides maximum storage in minimum floor space and makes inventory control easier.

Constructed of structural channel and 10 ga. steel sheet, this rack provides a hefty 6500 lb. capacity per bay. Racks are shipped knocked down and assemble easily without special tools. Gray enamel finish.

A connector channel is available to accommodate add-on units. Simply bolt one end of connector channel to the single hole at the end of the unit in use, then bolt the other end of the connector channel to the add-on unit making one extra bay. Different model numbers may be combined to form larger units—models are completely compatible with any size add-on. For example, by use of a connector channel, two VSR3 units can be combined to provide 7 bays of storage.

• ALL MODELS ARE 31" HIGH

MODEL NO.	NO. OF BAYS	WIDTH	LENGTH	CAPACITY	WEIGHT
VSR1	1	84"	40"	6,500 lbs	257 lbs
VSR3	3		80"	19,500 lbs	570 lbs
VSR5	5		120"	32,500 lbs	882 lbs
VSRC	Connector Channel		80"		58 lbs

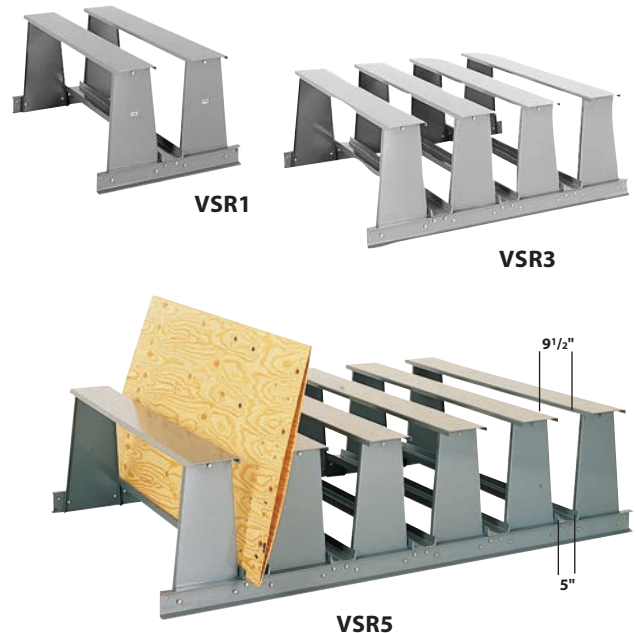

BAR STORAGE RACKS

STORE SHORT LENGTHS OF BAR STOCK, PIPE OR TUBING QUICKLY AND EFFICIENTLY

The **Horizontal Bar Rack** stores lengths of stock up to 10' on one unit. Two units handle lengths to 20'. The Horizontal Bar Rack features 9 storage levels on 9" arms spaced 6" apart. The 30" x 30" base ensures stability and reduces chance of tipping.

The **Vertical Bar Rack** handles odd lengths of material from 21" to 12'. Arms extend 8" from the frame and divide the rack into thirds for orderly on-end storage. Additional material may be stored horizontally on three 16 ga. steel shelves.

Both units finished with gray enamel.

• UNITS SHIP KNOCKED DOWN IN A CARTON VIA UPS

MODEL NO.	LENGTH	DEPTH	HEIGHT	CAPACITY	WEIGHT
BSRH1-KD	30"	30"	84"	1800 lbs	117 lbs
BSRV1-KD	36"	24"		3000 lbs	141 lbs



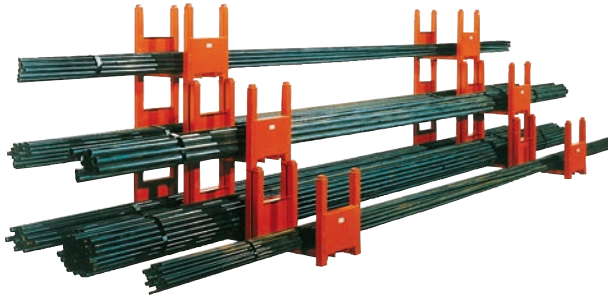

STEEL STACKS

MODULAR • STACKABLE WELDED STEEL STORAGE RACKS • FLEXIBLE, LOW COST STORAGE SYSTEM FITS ANY SPACE

Steel Stacks are the answer to changing storage needs. Welded steel construction yet light weight—they can be easily shifted or changed as requirements change and stack safely up to four units high. Additions are inexpensive and easy to make—no tools required during initial set-up or moving. Steel Stacks are completely assembled and ready for instant use. Capacities up to 7500 lbs. each. Ideal for storing bar stock, pipe, tubing, molding, specialty lumber and parts. Used for storage of those small heavy items that do not store well on standard shelving. Low cost, maximum flexibility and minimum space requirements compare favorably to alternatives. Orange enamel finish.

• ECONOMICAL SPACE-SAVING STORAGE

MODEL NO.*	NO. OF SECTIONS	LENGTH	WIDTH	HEIGHT	CAPACITY/SECTION	WEIGHT
SSR1	1	16"	12"	13"	2500 lbs	17 lbs
SSR2		19"	14"	17"	3750 lbs	24 lbs
SSR3		22"	15"	20"	5600 lbs	35 lbs
SSR4		26"	16"	23"	7500 lbs	53 lbs
SSM1-2	2	30"	12"	13"	2500 lbs	32 lbs
SSM1-3	3	44"				44 lbs
SSM1-4	4	58"				55 lbs
SSM1-5	5	72"				66 lbs
SSM2-2	2	36"				14"
SSM2-3	3	53"	73 lbs			
SSM2-4	4	70"	97 lbs			
SSM2-5	5	87"	116 lbs			
SSM3-2	2	42"	15"	20"	5600 lbs	
SSM3-3	3	62"				86 lbs
SSM3-4	4	82"				111 lbs
SSM3-5	5	102"				135 lbs
SSM4-2	2	50"				16"
SSM4-3	3	74"	126 lbs			
SSM4-4	4	98"	185 lbs			
SSM4-5	5	102"	200 lbs			

* NOTE: THE FIRST NUMBER REFERS TO THE SIZE OF THE UNIT (SEE ILLUSTRATIONS AT LEFT). THE SECOND NUMBER REFERS TO THE NUMBER OF SECTIONS.

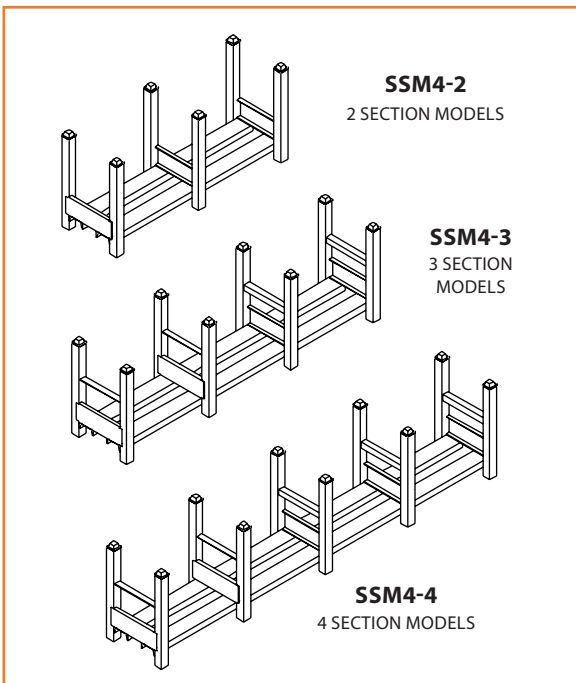
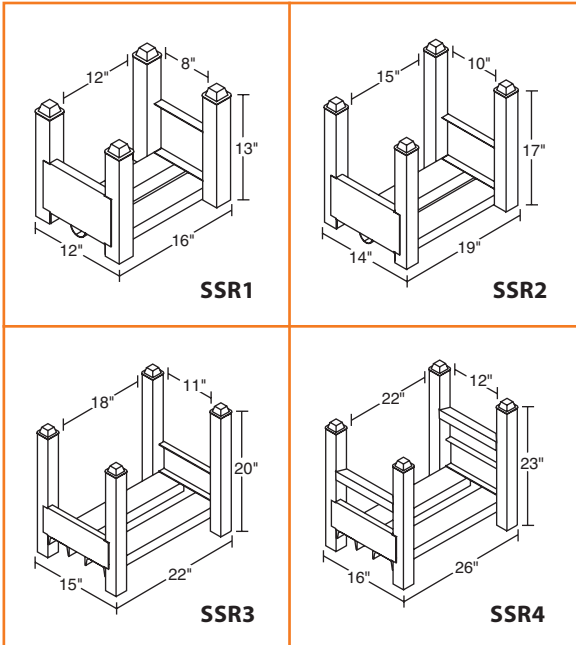

How to select Steel Stacks:

1. Consider length, weight and rigidity of material to be stored.
2. Determine modular capacity from tables.
3. Determine length of material to be stored and select number of units required from illustration at right.
4. Determine quantity and dimensions of units required from the above table.
5. Contact **MECO OMAHA** for special requirements.

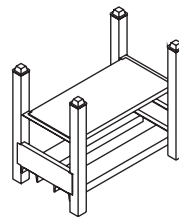
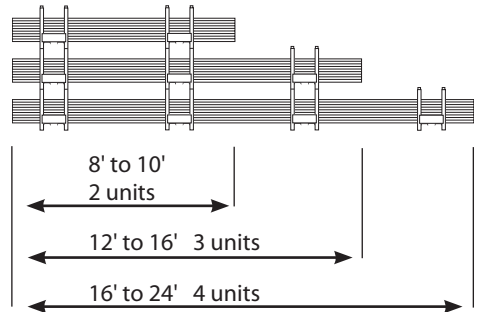

2-WAY SHELF
divides full capacity into 2 sections

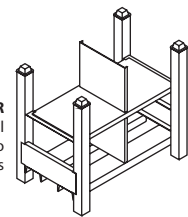

4-WAY DIVIDER
divides full capacity into 4 sections

• 2-WAY SHELVES AND 4-WAY DIVIDERS FOR STEEL STACKS

FOR USE WITH MODEL NUMBERS	2-WAY SHELF		4-WAY DIVIDER	
	MODEL NO.	WEIGHT	MODEL NO.	WEIGHT
SSR1 and SSM1	SSR1D	7 lbs	SSR1X	10 lbs
SSR2 and SSM2	SSR2D	8 lbs	SSR2X	14 lbs
SSR3 and SSM3	SSR3D	10 lbs	SSR3X	18 lbs
SSR4 and SSM4	SSR4D	14 lbs	SSR4X	25 lbs



ROLL-OUT SHELF RACKS

OFFER 100% SHELF EXTENSION FOR CONVENIENT LOADING AND UNLOADING

The Roll-Out Shelf Rack from **MECO OMAHA** is at home in virtually any industry from manufacturing to warehousing. Ideal for roll-out storage of dies, fixtures, engine parts, tooling or items that require secure storage with easy access. Each shelf handles 2000 lbs. of product; items can be loaded or unloaded by overhead crane or forklift. Store up to 2000 lbs. on the top of the unit.

Structural 3" channel frame is punched to permit 2" vertical adjustability of shelves while providing superior strength and durability. Shelves of 10 ga. steel roll out one at a time and lock in the extended position for maximum safety.

The Roll-Out Shelf Rack is available in three heights and three shelf sizes. Three shelf or four shelf models available. The basic starter units can be expanded to meet ever-changing storage requirements with add-on units. Ships knocked down for freight savings; gray enamel finish.

In addition to our knocked-down units, we now offer fully assembled units, shipped ready for use. Contact us for assembled pricing.

• 2000 LB CAPACITY PER SHELF

STARTER UNITS					
MODEL NO.	DIMENSIONS*			NO. OF SHELVES	WEIGHT
	SHELF WIDTH	DEPTH	HEIGHT		
RSR335-3	36"	36"	62"	3	918 lbs
RSR435-3	48"				1044 lbs
RSR445-3	48"	48"	1227 lbs		
RSR336-3	36"	36"	72"		936 lbs
RSR436-3	48"				1061 lbs
RSR446-3	48"	48"	1244 lbs		
RSR337-4	36"	36"	85"	4	1170 lbs
RSR437-4	48"				1332 lbs
RSR447-4	48"	48"	1526 lbs		

* DEPTH AND HEIGHT FIGURES REPRESENT OVERALL DIMENSIONS. ADD 8" TO SHELF WIDTH FIGURE FOR OVERALL WIDTH DIMENSION.

• 2000 LB CAPACITY PER SHELF

ADD-ON UNITS					
MODEL NO.	DIMENSIONS*			NO. OF SHELVES	WEIGHT
	SHELF WIDTH	DEPTH	HEIGHT		
RSR335-3A	36"	36"	62"	3	850 lbs
RSR435-3A	48"				975 lbs
RSR445-3A	48"	48"	1153 lbs		
RSR336-3A	36"	36"	72"		859 lbs
RSR436-3A	48"				984 lbs
RSR446-3A	48"	48"	1162 lbs		
RSR337-4A	36"	36"	85"	4	1083 lbs
RSR437-4A	48"				1244 lbs
RSR447-4A	48"	48"	1470 lbs		

* DEPTH AND HEIGHT FIGURES REPRESENT OVERALL DIMENSIONS. OVERALL WIDTH WILL INCREASE BY 4" WHEN ADDED TO A STARTER UNIT.



RSR337-4
ROLL-OUT SHELF RACK



RSR337-4
ROLL-OUT SHELF RACK
With Shelf Extended



200PN
CONVERTIBLE
2-IN-1 TRUCK

200 SERIES CONVERTIBLE 2-IN-1 TRUCK

A 2 WHEEL HAND TRUCK OR A 4 WHEEL PLATFORM TRUCK

The **MECO OMAHA** 2-in-1 Truck converts from a 2 wheel hand truck to a 4 wheel platform truck in seconds—no tools required. As a platform truck the usable deck space is a generous 14" wide x 36" long. The 7 ga. x 8" x 14" toe plate contains the load in the horizontal or vertical position. Available with commercial duty 8" semi-pneumatic wheels or industrial duty 10" full pneumatic wheels. Orange enamel finish.

• SHIPS VIA UPS

MODEL NO.	WHEELS	CAPACITY	HANDLE HEIGHT	OVERALL WIDTH	WEIGHT
200SP	8" x 1 3/4" Semi-Pneumatic	300 lbs - 2 Whl	46" & 68"	20"	35 lbs
	3" Rubber Swivel Casters	450 lbs - 4 Whl	45" - 4 Whl		
200PN	10" x 3 1/2" Full Pneumatic	600 lbs - 2 Whl	46" & 68"	21 1/4"	41 lbs
	5" Rubber Swivel Casters	600 lbs - 4 Whl	46" - 4 Whl		

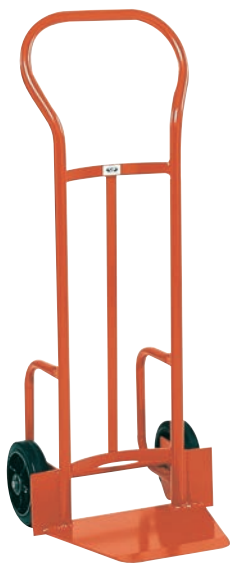

82H
HEAVYWEIGHT
SHOVEL TRUCK

HEAVYWEIGHT SHOVEL TRUCK

A REAL BRUTE • VIRTUALLY INDESTRUCTIBLE

This **MECO OMAHA** Heavyweight Shovel Truck is designed for heavy duty performance and rough use. The 1 1/4" diameter frame is all double welded. The 5/16" steel toe plate is 14" long and tapers from 17" at the rear to 11" at the front—beveled and rounded for easy loading. Equipped with 1 1/16" diameter stairglides behind wheels for ease in maneuvering over curbs and up stairs. Heavy fenders keep wide loads from rubbing wheels. The Heavyweight is equipped with 8" x 2" mold-on rubber or steel wheels with roller bearings and grease fittings; 3/4" cold drawn steel axle. Also available with plain bore polyolefin wheels. A truly heavy duty truck!

• 17" X 14" TOE PLATE

MODEL NO.	WHEELS	HEIGHT	WIDTH	CAPACITY	WEIGHT
82H	8" x 2" Mold-On Rubber	50"	19 3/4"	1000 lbs	59 lbs
92H	8" x 2" Steel			1500 lbs	70 lbs
82P	8" x 2" Polyolefin			52 lbs	

6 YEAR GUARANTEE AGAINST FRAME BREAKAGE



54VR
FOUR WHEEL
WAREHOUSE TRUCK

FOUR WHEEL WAREHOUSE TRUCK

IDEAL FOR PALLET LOADING AND UNLOADING

MECO OMAHA's heavy duty Warehouse Truck is perfectly balanced for easy breaking back over rear wheels. The heavy duty 1 1/4" diameter frame is double welded to ensure long life. The 1/4" steel toe plate is 14" long and tapers from 18" at the rear to 11 1/2" at the front—beveled and rounded for easy loading. Available with 10" x 2 1/2" steel or mold-on rubber wheels with roller bearings and grease fittings; polyolefin wheels have a plain bore.

• 1000 LB CAPACITY

MODEL NO.	WHEELS	HEIGHT	WIDTH	WEIGHT
54VR	2 - 10" x 2 1/2" Mold-On Rubber 2 - 6" x 2" Mold-On Rubber	62"	24 1/2"	93 lbs
54SS	2 - 10" x 2 1/2" Steel 2 - 6" x 2" Steel			96 lbs
54P	2 - 10" x 2 1/4" Polyolefin 2 - 6" x 2" Polyolefin			67 lbs

6 YEAR GUARANTEE AGAINST FRAME BREAKAGE



200 SERIES HAND TRUCKS

STANDARD HAND TRUCKS

The 200 Series Hand Trucks from **MECO OMAHA** provide the most popular hand truck styles and options. Choose a one or two pin, flow back, loop or standard two handle model and a height that matches the truck to the job. Many of **MECO OMAHA**'s standard features are high priced options with other manufacturers.

200 Series Hand Trucks employ a durable 1" diameter double welded steel frame to withstand a variety of operating conditions and ensure years of service. A full height vertical brace adds strength and rigidity, three cross straps contain virtually any load. The large 7 ga. x 8" x 14" steel toe plate is beveled for easy loading; rounded corners prevent serious damage to product, equipment and personnel. Steel wheel guards protect the load and permit free wheel rotation.

Standard Hand Trucks are available 46" high for normal operation or 50" high for high-stacking capabilities. Choice of 10" semi-pneumatic or 10" full pneumatic ball bearing wheels; orange enamel finish.

• SHIPS VIA UPS

MODEL NO.	WHEELS	CAPACITY	HEIGHT	OVERALL WIDTH	WEIGHT
200SP	8" x 1 3/4" Semi-Pneumatic 3" Rubber Swivel Casters	300 lbs - 2 Whl 450 lbs - 4 Whl	46" & 68"	20"	35 lbs
200PN	10" x 3 1/2" Full Pneumatic 5" Rubber Swivel Casters	600 lbs - 2 Whl 600 lbs - 4 Whl	46" & 68"	21 1/4"	41 lbs
210SP	10" x 2 3/4" Semi-Pneumatic	500 lbs	46"	20"	34 lbs
210PN	10" x 3 1/2" Full Pneumatic	600 lbs		21 1/4"	32 lbs
250SP	10" x 2 3/4" Semi-Pneumatic	500 lbs	50"	20"	33 lbs
250PN	10" x 3 1/2" Full Pneumatic	600 lbs		21 1/4"	31 lbs
251SP	10" x 2 3/4" Semi-Pneumatic	500 lbs		20"	33 lbs
251PN	10" x 3 1/2" Full Pneumatic	600 lbs		21 1/4"	31 lbs
252SP	10" x 2 3/4" Semi-Pneumatic	500 lbs	46"	20"	35 lbs
252PN	10" x 3 1/2" Full Pneumatic	600 lbs		21 1/4"	33 lbs
260SP	10" x 2 3/4" Semi-Pneumatic	500 lbs	46"	20"	32 lbs
260PN	10" x 3 1/2" Full Pneumatic	600 lbs		21 1/4"	30 lbs



210SP
46" Height
Flow Back Handle



250SP
50" Height
Loop Handle



251SP
50" Height
1 Pin Handle

SEE PAGE 35 FOR OUR POPULAR 200 SERIES 2-IN-1 CONVERTIBLE TRUCK



252SP
50" Height
2 Pin Handle



260SP
46" Height
Standard 2 Handle

• INDUSTRIAL STRENGTH • TWO YEAR WARRANTY

WORLD'S FINEST HAND TRUCKS

200 SERIES HAND TRUCKS

MADE IN U.S.A.

200 SERIES HAND TRUCKS

DELUXE HAND TRUCKS WITH STAIRGLIDES

The Deluxe Hand Trucks incorporate all the fine features of our Standard Hand Truck line plus offer tubular steel stairglides. Stairglides, a feature found on much costlier units, make climbing stairs and curbs almost effortless.

Deluxe Hand Trucks are available with a one pin, two pin or loop handle in 46" and 50" heights. All models offer a cushion ride on 10" semi-pneumatic or full pneumatic ball bearing wheels; orange enamel finish.

• SHIPS VIA UPS

MODEL NO.	WHEELS	CAPACITY	HEIGHT	OVERALL WIDTH	WEIGHT
280SP	10" x 2 3/4" Semi-Pneumatic	500 lbs	46"	20"	32 lbs
280PN	10" x 3 1/2" Full Pneumatic	600 lbs		21 1/4"	30 lbs
281SP	10" x 2 3/4" Semi-Pneumatic	500 lbs		20"	32 lbs
281PN	10" x 3 1/2" Full Pneumatic	600 lbs		21 1/4"	30 lbs
282SP	10" x 2 3/4" Semi-Pneumatic	500 lbs	50"	20"	32 lbs
282PN	10" x 3 1/2" Full Pneumatic	600 lbs		21 1/4"	30 lbs
290SP	10" x 2 3/4" Semi-Pneumatic	500 lbs		20"	36 lbs
290PN	10" x 3 1/2" Full Pneumatic	600 lbs		21 1/4"	34 lbs
291SP	10" x 2 3/4" Semi-Pneumatic	500 lbs	50"	20"	36 lbs
291PN	10" x 3 1/2" Full Pneumatic	600 lbs		21 1/4"	34 lbs
292SP	10" x 2 3/4" Semi-Pneumatic	500 lbs		20"	37 lbs
292PN	10" x 3 1/2" Full Pneumatic	600 lbs		21 1/4"	35 lbs



280SP
46" Height
Loop Handle



281SP
46" Height
1 Pin Handle



282SP
46" Height
2 Pin Handle



290SP
50" Height
Loop Handle



291SP
50" Height
1 Pin Handle



292SP
50" Height
2 Pin Handle



HEAVY DUTY SHELF TRUCKS

RUGGED, MULTI-USE TRUCKS FOR THE SHOP, FACTORY, WAREHOUSE OR SHIPPING ROOM • COMPLETE LINE

MECO OMAHA manufactures a complete line of shelf trucks, platform trucks and service carts to meet nearly all your material handling requirements. These trucks feature all double welded construction and heavy gauge steel shelves for years of industrial

use. **MECO OMAHA** offers one, two, three and five shelf units with a wide choice of casters including rubber, steel, polyolefin, phenolic or full pneumatic on selected models; capacities to 4000 lbs. All models are finished with gray enamel and ship fully assembled.



SPT9R

STEEL PARTS TRUCK

THIS POPULAR MODEL HAS BEEN MANUFACTURED BY MECO OMAHA FOR OVER 40 YEARS

- Trucks roll smoothly on two swivel/two rigid casters welded to truck, plain bore wheels
- Top shelf available with lip down—add suffix “-LD” to model number
- Smooth, round push handle extends the full width of truck for comfortable operation
- 23" clearance between shelves

• 16 GA. HEMMED STEEL SHELVES • 2" DEEP FORMED LIP

MODEL NO.	SHELF SIZE	SHELF HEIGHT	CASTERS	CAPACITY	WEIGHT
SPT7R	16" x 28"	33"	4" Rubber	1000 lbs	58 lbs
SPT7S			4" Steel		62 lbs
SPT9R	4" Rubber		69 lbs		
SPT9S	4" Steel		72 lbs		

• 12 GA. STEEL SHELVES • 2" DEEP FORMED LIPS ARE NOT HEMMED

MODEL NO.	SHELF SIZE	SHELF HEIGHT	CASTERS	CAPACITY	WEIGHT
SPT2436R	24" x 36"	33"	4" Rubber	1000 lbs	104 lbs
SPT2436S			4" Steel		107 lbs

HUSKY SERVICE TRUCK

- Available with 2 or 3 shelves of 12 ga. steel, 2" lip
- Units will be shipped with shelf lips down. Top and middle shelves available with lip up—add suffix “-LU” to model number
- Welded stiffener bars keep shelves rigid
- Trucks move effortlessly on two swivel/two rigid bolt on casters, roller bearing wheels
- Full width push handle for operating ease



HSC24-24

(Diagram indicates placement of optional third shelf)

HUSKY SERVICE CART

SELECT 2 OR 3 SHELF MODELS ALL WITH 4000 LB CAPACITY

• TWO SHELF MODELS • 23" CLEARANCE BETWEEN SHELVES

MODEL NO.	SHELF SIZE	SHELF HEIGHT	CASTERS	CAPACITY	WEIGHT
HSC24-23	24" x 36"	36"	8" x 2" Phenolic	4000 lbs	164 lbs
HSC24-24	24" x 48"				185 lbs
HSC24-25	24" x 60"				212 lbs
HSC24-26	24" x 72"				240 lbs
HSC28-24	28" x 48"				201 lbs
HSC28-25	28" x 60"				231 lbs
HSC28-26	28" x 72"				261 lbs
HSC34-24	34" x 48"				225 lbs
HSC34-25	34" x 60"				258 lbs
HSC34-26	34" x 72"				278 lbs

• THREE SHELF MODELS • 10 1/2" CLEARANCE BETWEEN SHELVES

MODEL NO.	SHELF SIZE	SHELF HEIGHT	CASTERS	CAPACITY	WEIGHT
HSC24-33	24" x 36"	36"	8" x 2" Phenolic	4000 lbs	205 lbs
HSC24-34	24" x 48"				242 lbs
HSC24-35	24" x 60"				282 lbs
HSC24-36	24" x 72"				324 lbs
HSC28-34	28" x 48"				264 lbs
HSC28-35	28" x 60"				309 lbs
HSC28-36	28" x 72"				354 lbs
HSC34-34	34" x 48"				298 lbs
HSC34-35	34" x 60"				348 lbs
HSC34-36	34" x 72"				385 lbs



STOCK TRUCK

DOUBLE WELDED UNITS OUTLAST AND OUTPERFORM SIMILAR BOLT TOGETHER MODELS

- Smooth 12 ga. steel shelves, 2" upward lip on bottom shelf
- Top shelf available with lip up—add suffix “-LU” to model number
- Rugged 1³/₈" diameter handle extends 9¹/₂" above top shelf
- Two swivel/two rigid casters bolted to caster plates, plain bore wheels; 8" full pneumatic wheels have ball bearings

• TWO SHELF MODELS • 19" CLEARANCE BETWEEN SHELVES

MODEL NO.	SHELF SIZE	SHELF HEIGHT	CASTERS	CAPACITY	WEIGHT
ST11-5	24" x 36"	30 ³ / ₄ "	5" x 1 ¹ / ₄ " Rubber	800 lbs	107 lbs
ST12-5	24" x 48"				128 lbs
ST13-5	30" x 60"				173 lbs
ST11-6	24" x 36"	32 ¹ / ₄ "	6" x 2" Polyolefin	1200 lbs	112 lbs
ST12-6	24" x 48"				133 lbs
ST13-6	30" x 60"				178 lbs
ST11-8	24" x 36"	34 ¹ / ₄ "	8" x 2" Polyolefin	2000 lbs	124 lbs
ST12-8	24" x 48"				145 lbs
ST13-8	30" x 60"				190 lbs
ST11-8PN	24" x 36"	34 ¹ / ₂ "	8" Full Pneumatic	1200 lbs	138 lbs
ST12-8PN	24" x 48"				158 lbs
ST13-8PN	30" x 60"				203 lbs



ST11-5

INSTRUMENT CART

DESIGNED TO REDUCE SHOCK AND VIBRATION FOUND IN OTHER TYPES OF SHELF TRUCKS AND CARTS

- Incorporates all the fine features of the Stock Truck depicted above including two sturdy 12 ga. shelves
- 8" full pneumatic casters with ball bearing wheels and rubber shelf mats combine to cushion delicate instruments and tools
- Top shelf available with lip up—add suffix “-LU” to model number
- The finest instrument cart on the market today

• TWO SHELF MODELS • 19" CLEARANCE BETWEEN SHELVES

MODEL NO.	SHELF SIZE	SHELF HEIGHT	CASTERS	CAPACITY	WEIGHT
IC11-8PN	24" x 36"	34 ¹ / ₂ "	8" Full Pneumatic	1200 lbs	141 lbs
IC12-8PN	24" x 48"				162 lbs
IC13-8PN	30" x 48"				174 lbs
IC14-8PN	30" x 60"				248 lbs



IC11-8PN

WELDED SERVICE CART

DOUBLE WELDED SERVICE CART BUILT FOR THE ECONOMY-MINDED

- 12 ga. steel shelves have a 2" upward lip—for all lips down add suffix “-LD” to model number
- 5" all-swivel rubber stem casters are non-marking
- Choice of 2 or 3 shelf models
- Ideal for light to medium duty applications

• TWO SHELF MODELS • 23" CLEARANCE BETWEEN SHELVES

MODEL NO.	SHELF SIZE	SHELF HEIGHT	CASTERS	CAPACITY	WEIGHT
WSC1830-2	18" x 30"	35"	5" x 1" Rubber	500 lbs	67 lbs
WSC1836-2	18" x 36"				75 lbs
WSC2436-2	24" x 36"				91 lbs
WSC2448-2	24" x 48"				111 lbs

• THREE SHELF MODELS • 10¹/₂" CLEARANCE BETWEEN SHELVES

MODEL NO.	SHELF SIZE	SHELF HEIGHT	CASTERS	CAPACITY	WEIGHT
WSC1830-3	18" x 30"	35"	5" x 1" Rubber	500 lbs	90 lbs
WSC1836-3	18" x 36"				102 lbs
WSC2436-3	24" x 36"				124 lbs
WSC2448-3	24" x 48"				153 lbs



WSC1836-2

(Diagram indicates placement of optional third shelf)



MOBILE STEEL TABLES IDEAL FOR TRANSFERRING WORK IN-PROCESS FROM ONE LOCATION TO THE NEXT

- Heavy duty steel angle framework and 12 ga. steel shelves with 2" downward lip
- One or two shelves can be field installed on the one shelf model with simple nut and bolt assembly
- Four popular shelf sizes with an option of three bolt-on caster styles; wheels have bearings for smooth operation

CHOICE OF ONE, TWO OR THREE SHELF MODELS

SHELF SIZE	SHELF HEIGHT	CASTERS	1 SHELF MODEL		2 SHELF MODEL		3 SHELF MODEL	
			MODEL NO.	WEIGHT	MODEL NO.	WEIGHT	MODEL NO.	WEIGHT
24" x 36"	31 1/4"	5" x 2" Mold-On Rubber Two Swivel/Two Rigid 1400 lbs capacity	5MS243-1	102	5MS243-2	136	5MS243-3	170
24" x 48"			5MS244-1	115	5MS244-2	159	5MS244-3	203
30" x 48"			5MS304-1	129	5MS304-2	182	5MS304-3	236
30" x 60"			5MS305-1	144	5MS305-2	210	5MS305-3	276
24" x 36"	32"	6" x 2" Polyolefin Two Swivel/Two Rigid 3000 lbs capacity	6MS243-1	108	6MS243-2	142	6MS243-3	176
24" x 48"			6MS244-1	124	6MS244-2	168	6MS244-3	212
30" x 48"			6MS304-1	137	6MS304-2	191	6MS304-3	244
30" x 60"			6MS305-1	158	6MS305-2	224	6MS305-3	289
24" x 36"	34 1/4"	8" Full Pneumatic Two Swivel/Two Rigid 1200 lbs capacity	8MS243-1	115	8MS243-2	149	8MS243-3	183
24" x 48"			8MS244-1	129	8MS244-2	173	8MS244-3	217
30" x 48"			8MS304-1	142	8MS304-2	196	8MS304-3	249
30" x 60"			8MS305-1	158	8MS305-2	224	8MS305-3	289



8MS244-1
20 3/4" clearance
between shelf and frame



6MS244-2
18 1/2" clearance between shelves



5MS244-3
9 1/2" clearance between top and middle shelf
7" clearance between middle and bottom shelf



OPT2

ORDER PICKING TRUCK

FOR A VARIETY OF ORDER PICKING AND INVENTORY FUNCTIONS

- Both 16 ga. steel shelves have a hemmed 2" upward lip—no sharp edges
- Hefty steel angle frame withstands the rigors of an order picking environment
- Two swivel/two rigid casters are welded to the truck; plain bore wheels
- 12 ga. steel writing area is gusseted for additional strength; 12" x 18" and 12" x 24" surface has a 2" lip to contain work orders, labels, bar code readers, pens and pencils
- Overall height of the unit is 43"

TWO SHELF MODELS • 26 1/2" CLEARANCE BETWEEN SHELVES

MODEL NO.	SHELF SIZE	SHELF HEIGHT	CASTERS	CAPACITY	WEIGHT
OPT1	18" x 36"	36 1/2"	5" x 1 1/4" Rubber	600 lbs	78 lbs
OPT2	24" x 36"				90 lbs



TC1



TC2

TOOL CART

AN INDISPENSIBLE CART IN FACTORIES, WAREHOUSES, MACHINE SHOPS AND MAINTENANCE DEPARTMENTS

- Three 12 ga. steel shelves provide adequate space for tools and accessories; bottom and middle shelves enclosed by a 2" upward lip—top shelf has one side open
- All-swivel casters for extremely high maneuverability; casters are welded to the cart
- The model TC2 employs an additional top half-shelf for smaller items, clipboards and notebooks; half-shelf increases height to 39 1/2"

THREE SHELF MODELS • 10 1/2" CLEARANCE BETWEEN SHELVES

MODEL NO.	SHELF SIZE	SHELF HEIGHT	CASTERS	CAPACITY	WEIGHT
TC1	20" x 27"	31 1/2"	3" x 1 1/4" Polyurethane	900 lbs	86 lbs
TC2					102 lbs



MOBILE MACHINE TABLES

HEAVY DUTY MOBILE TABLES IDEAL FOR USE IN THE FACTORY OR SHOP

- Heavy Duty 2" x 2" x 3/16" Angle Legs Support the Most Demanding Load
- Smooth 12 ga. Steel Shelves Will Not Crack, Splinter or Absorb Liquids
- 3000 lb. Unit: Shelves Have Welded Stiffener Bars to Keep Shelves Rigid
- Four 3" Polyolefin Swivel Casters with Brakes
- Gray Enamel Finish

• TWO SHELVES • 2000 lb. CAPACITY

MODEL NO.	SHELF SIZE	SHELF CLEARANCE	HEIGHT	WEIGHT
MMT1823-2C	18" x 36"	20 1/4"	32 1/4"	70 lbs
MMT2423-2C	24" x 36"			84 lbs
MMT2424-2C	24" x 48"			105 lbs
MMT2425-2C	24" x 60"			127 lbs

• THREE SHELVES • 2000 lb. CAPACITY

MODEL NO.	SHELF SIZE	SHELF CLEARANCE	HEIGHT	WEIGHT
MMT1833-2C	18" x 36"	9 1/8"	32 1/4"	97 lbs
MMT2433-2C	24" x 36"			117 lbs

• TWO SHELVES • 3000 lb. CAPACITY

MODEL NO.	SHELF SIZE	SHELF CLEARANCE	HEIGHT	WEIGHT
MMT2424-3C	24" x 48"	24 1/2"	36 1/4"	143 lbs
MMT2824-3C	28" x 48"			156 lbs
MMT3424-3C	34" x 48"			175 lbs
MMT3426-3C	34" x 72"			259 lbs



MMT2424-3C



MMT2433-2C

WORK WITH A WINNER!

REASONS WHY YOU WILL WIN WITH MECO OMAHA

1. We sell only through our Dealers and Distributors
2. Calling our friendly MECO OMAHA sales staff will assure you the absolute lowest competitive price
3. Same Day Quotes! No job is too small for us to quote
4. Quick Ship Times
5. A commitment to Quality, Integrity and Service to our Dealers

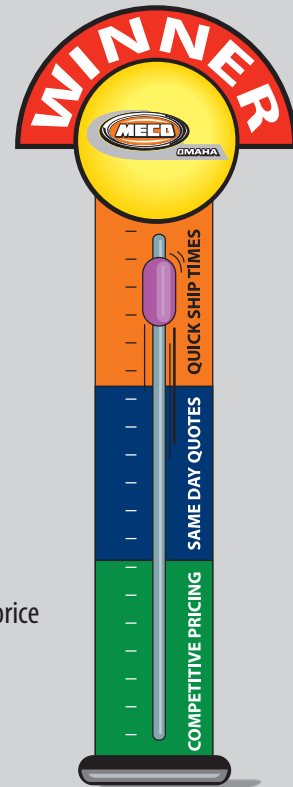



MT-2436
TWO SHELF MACHINE TABLE

MACHINE TABLES

CHOICE OF ALL WELDED CONSTRUCTION OR BOLT-TOGETHER, KNOCKED DOWN MODEL

These all-steel tables are ideal for tool and die work, assembly operations, maintenance projects and as platforms for drill presses, table saws and belt sanders. Four solid steel angle legs support the most demanding loads. The smooth 12 ga. steel shelves will not crack, splinter or absorb liquids—maintenance is easy! Available in three comfortable working heights. All units are shipped fully assembled; gray enamel finish.

The **3000 LB. CAPACITY TABLES** employ heavy steel angle reinforcements under the shelves to maintain flatness while improving strength and rigidity.

• 2000 LB CAPACITY • ALL SHELF EDGES TURNED DOWN

MODEL NO.	SHELF SIZE	NO. OF SHELVES	SHELF CLEARANCE	HEIGHT	WEIGHT
MT-1824	18" x 24"	2	18"	30"	63 lbs
MT-1836	18" x 36"				79 lbs
MT-2424	24" x 24"				73 lbs
MT-2436	24" x 36"				93 lbs
MT-2448	24" x 48"				113 lbs

• 2000 LB CAPACITY • TOP SHELF EDGES TURNED DOWN • OTHER SHELF EDGES TURNED UP



MMT2433-2
THREE SHELF MACHINE TABLE

MODEL NO.	SHELF SIZE	NO. OF SHELVES	SHELF CLEARANCE	HEIGHT	WEIGHT
MMT1823-2	18" x 36"	2	22 ¹ / ₄ "	32"	74 lbs
MMT2423-2	24" x 36"				88 lbs
MMT2424-2	24" x 48"				109 lbs
MMT2425-2	24" x 60"				131 lbs
MMT3025-2	30" x 60"				152 lbs
MMT1833-2	18" x 36"	3	10 ¹ / ₈ "	32"	101 lbs
MMT2433-2	24" x 36"				121 lbs
MMT3035-2	30" x 60"				218 lbs

• 3000 LB CAPACITY • ALL SHELF EDGES TURNED DOWN • HEAVY DUTY LEGS FOR INCREASED CAPACITY • SHELVES REINFORCED BY ANGLE IRON

MODEL NO.	SHELF SIZE	NO. OF SHELVES	SHELF CLEARANCE	HEIGHT	WEIGHT
MMT2424-3	24" x 48"	2	24 ¹ / ₂ "	36"	147 lbs
MMT2824-3	28" x 48"				160 lbs
MMT3025-3	30" x 60"				198 lbs
MMT3424-3	34" x 48"				179 lbs
MMT3426-3	34" x 72"				263 lbs



MT2448-KD
MACHINE TABLE
(Optional shelf is supported by angle braces)

KNOCKED DOWN MACHINE TABLES assemble easily—no special tools required. This unit has one shelf and two lengthwise angle support braces. Optional second shelf can be installed with 1¹/₂" lip up or down. Gray enamel finish; ships via UPS.

• 1000 LB CAPACITY • ALL SHELF EDGES TURNED DOWN

MODEL NO.	SHELF SIZE	NO. OF SHELVES	SHELF CLEARANCE	HEIGHT	WEIGHT
MT1836-KD	18" x 36"	1	18"	30"	71 lbs
MT2436-KD	24" x 36"				80 lbs
MT2448-KD	24" x 48"				93 lbs

OPTIONAL SHELF FOR KNOCKED DOWN MODEL • 1000 LB CAPACITY

MODEL NO.	SHELF SIZE	NO. OF SHELVES	SHELF CLEARANCE	HEIGHT	WEIGHT
MTS1836	18" x 36"	1	16 ¹ / ₂ " with lip up 18" with lip down	1 ¹ / ₂ "	27 lbs
MTS2436	24" x 36"				34 lbs
MTS2448	24" x 48"				44 lbs



FIVE SHELF SERVICE CARTS

THE ULTIMATE SERVICE CART. HAUL HEAVY CARTONS, MACHINE PARTS, DIES AND TOOLS EFFICIENTLY

• 800 LB CAPACITY • 10" CLEARANCE BETWEEN SHELVES

MODEL NO.	SHELF SIZE	OVERALL HEIGHT	CASTERS	CAPACITY	WEIGHT
SC1836-5	18" x 36"	58"	5" x 1 1/4" Rubber	800 lbs	175 lbs
SC2436-5	24" x 36"				215 lbs
SC2448-5	24" x 48"				265 lbs
SC2460-5	24" x 60"				316 lbs
SC3048-5	30" x 48"				316 lbs
SC3060-5	30" x 60"				377 lbs
SC3660-5	36" x 60"				439 lbs
SC3672-5	36" x 72"				511 lbs

• 3000 LB CAPACITY • 12" CLEARANCE BETWEEN SHELVES

MODEL NO.	SHELF SIZE	OVERALL HEIGHT	CASTERS	CAPACITY	WEIGHT
SC1836-8	18" x 36"	69 1/2"	8" x 2" Polyolefin	3000 lbs	220 lbs
SC2436-8	24" x 36"				259 lbs
SC2448-8	24" x 48"				310 lbs
SC2460-8	24" x 60"				360 lbs
SC3048-8	30" x 48"				360 lbs
SC3060-8	30" x 60"				421 lbs
SC3660-8	36" x 60"				483 lbs
SC3672-8	36" x 72"				555 lbs



SC2448-8

- Choice of high quality 5" rubber or 8" polyolefin casters, two swivel/two rigid combination
- All shelves have a 2" upward lip and are fabricated from thick 12 ga. steel, 8 different shelf sizes available
- Hefty 3/4" round steel push handle for easy operation
- Shipped completely assembled

STEEL PLATFORM TRUCKS

FEATURES HEAVY DUTY 12 GA. REINFORCED STEEL DECK—WILL NOT WARP, SPLINTER OR ABSORB LIQUIDS

• HANDLE EXTENDS 28" ABOVE DECK

MODEL NO.	SHELF SIZE	CASTERS	CAPACITY	WEIGHT
PT2436-5	24" x 36"	5" x 2" Mold-On Rubber	1400 lbs	96 lbs
PT2448-5	24" x 48"			113 lbs
PT3048-5	30" x 48"			124 lbs
PT3060-5	30" x 60"			144 lbs
PT3672-5	36" x 72"			179 lbs
PT2436-6	24" x 36"	6" x 2" Mold-On Rubber	1600 lbs	100 lbs
PT2448-6	24" x 48"			117 lbs
PT3048-6	30" x 48"			128 lbs
PT3060-6	30" x 60"			148 lbs
PT3672-6	36" x 72"			183 lbs
PT2436-8	24" x 36"	8" x 2" Mold-On Rubber	2000 lbs	111 lbs
PT2448-8	24" x 48"			128 lbs
PT3048-8	30" x 48"			140 lbs
PT3060-8	30" x 60"			159 lbs
PT3672-8	36" x 72"			194 lbs
PT2436-8PN	24" x 36"	8" Full Pneumatic	1200 lbs	109 lbs
PT2448-8PN	24" x 48"			126 lbs
PT3048-8PN	30" x 48"			137 lbs
PT3060-8PN	30" x 60"			157 lbs
PT3672-8PN	36" x 72"			192 lbs



PT2448-8PN

- Lengthwise steel battens reinforce the deck, provide rigidity and permit capacities to 2000 lbs.
- 1 1/8" removable pipe handle has 3 cross members to assist in containing the load
- Choice of 4 caster styles in a two swivel/two rigid combination, casters are welded to unit for long life; wheels have bearings for smooth operation



THREE-SIDED SERVICE CARTS

ALL UNITS HAVE 2400 LBS. CAPACITY TO HANDLE YOUR HEAVIEST LOADS

- Standard Color is Gray, for Optional Colors, Replace "-G" With the Following Suffixes: Red (-R), Yellow (-Y), Blue (-B)
- 12 ga. Steel Shelves Have a 2" Downward Lip and Are Double Welded To a Sturdy 1½" X 1½" Angle Frame
- Heavy Gauge ¾" Flattened Expanded Metal Makes Up The Sides and Ends
- Service Carts Move Effortlessly On 6" X 2" Polyurethane Casters (2 Swivel\2 Rigid) With 2400 lbs. Capacity
- Full Width ¾" Diameter Push Bar for Operating Ease



3S2448-3R-R
3-SHELF, 48" X 24" MODEL

• CARTS HAVE AN OVERALL HEIGHT OF 57"

MODEL NO.	SHELF SIZE	NO. OF SHELVES	SHELF CLEARANCE	WEIGHT
3S1836-2R-G	18" X 36"	2	23"	153 lbs.
3S1836-3R-G		3	14"	173 lbs.
3S2442-2R-G	24" X 42"	2	23"	171 lbs.
3S2442-3R-G		3	14"	212 lbs.
3S2448-1R-G	24" X 48"	1	-	152 lbs.
3S2448-2R-G		2	23"	196 lbs.
3S2448-3R-G		3	14"	240 lbs.
3S2460-2R-G	24" X 60"	2	23"	202 lbs.
3S2460-3R-G		3	14"	243 lbs.
3S2460-4R-G		4	10"	285 lbs.
3S3060-2R-G	30" X 60"	2	23"	252 lbs.
3S3060-3R-G		3	14"	304 lbs.
3S3060-4R-G		4	10"	356 lbs.
3S3672-1R-G	36" X 72"	1	-	265 lbs.
3S3672-3R-G		3	14"	377 lbs.



3S1836-2R-Y
2-SHELF, 36" X 18" MODEL



3S2448-1R-G
1-SHELF, 48" X 24" MODEL



3S3060-3R-B
3-SHELF, 60" X 30" MODEL



FOUR SHELF STOCK CART

SHELVES SLOPE 1" FROM FRONT TO BACK TO KEEP CARTONS IN PLACE DURING TRANSIT EXCEPT BOTTOM SHELF WHICH IS LEVEL

- Standard Color is Gray, for Optional Colors, Replace "-G" With the Following Suffixes: Red (-R), Yellow (-Y), Blue (-B)
- 12 ga. Steel Shelves Have a 2" Down Lip and are Double Welded to a Sturdy 1" Tubular Frame
- Contents are Contained by ½" Steel Round Bar on Back and Ends
- Stock Carts Move Effortlessly On 6" X 1½" Phenolic Casters (2 Swivel\2 Rigid) With 2000 lbs. Capacity



• CARTS HAVE AN OVERALL HEIGHT OF 62½"

MODEL NO.	SHELF SIZE	NO. OF SHELVES	SHELF CLEARANCE	WEIGHT
TS2448R-G	24" X 48"	4	14"	255 lbs.
TS2472R-G	24" X 72"			352 lbs.
TS3048R-G	30" X 48"			270 lbs.
TS3060R-G	30" X 60"			350 lbs.
TS3072R-G	30" X 72"			413 lbs.
TS3672R-G	36" X 72"			468 lbs.



TS3072R-B

OPEN-MESH SECURITY TRUCKS

STORE PROTECT AND TRANSPORT VALUABLE CARGO

- Standard Color for all Components is Gray, for Optional Colors, Replace "-G" With the Following Suffixes: Red (-R), Yellow (-Y), Blue (-B)
- Security Trucks Move Effortlessly On 5" X 2" Phenolic Casters (2 Swivel\2 Rigid) With 2400 lbs. Capacity
- Top and Bottom of All Units are Manufactured From Thick 12 ga. Steel
- Sides and Ends of ¾" Flattened Expanded Metal Surrounded By a Double Welded 1½" X 1½" Steel Angle Frame
- Contents are Secured By a Unique Locking Latch System - Can Be Padlocked
- Select the Optional 12 ga. Middle Shelf for Additional Storage (31½" Clearance Between Top and Bottom)
- Optional Fork Pockets Permit the Truck to be Moved or Lifted by Forklift



• TRUCKS HAVE AN OVERALL HEIGHT OF 74"

MODEL NO.	WIDTH	LENGTH	WEIGHT
OST2460R-G	24"	60"	345 lbs.
OST3048R-G	30"	48"	345 lbs.
OST3072R-G	30"	72"	385 lbs.
OST3672R-G	36"	72"	520 lbs.

• OPTIONAL MIDDLE SHELF

MODEL NO.	WIDTH	LENGTH	WEIGHT
OST2460R-MS-G	24"	60"	84 lbs.
OST3048R-MS-G	30"	48"	84 lbs.
OST3072R-MS-G	30"	72"	126 lbs.
OST3672R-MS-G	36"	72"	151 lbs.

• OPTIONAL FORK POCKETS

MODEL NO.	WIDTH	LENGTH	WEIGHT
OST-FP	6"	3"	29 lbs.



OST3048R-G

Shown with OST3048R-MS-G (optional middle shelf)
Shown here without Optional Fork Pockets



ADJUSTABLE PALLET STAND

HELPS ELIMINATE BACK STRAIN AND FATIGUE

The **MECO OMAHA** Adjustable Pallet Stand has three comfortable working heights and access from all sides. By grasping the safety handle the Adjustable Pallet Stand can be set up easily by just one person. A lock prevents the stand from folding while in use.

Made of sturdy structural channel, this all welded unit is designed for use in areas requiring high capacity support tables such as shipping rooms, machine shops and maintenance departments. Folds down to 8³/₄".

Choose model APS2C with two swivel/two rigid 5" x 2" phenolic casters for easy movement within the plant or shop.

Gray enamel finish.

• 4000 LB CAPACITY

MODEL NO.	TOP SIZE	ADJUSTING HEIGHTS	WEIGHT
APS2	40" x 40"	24" - 30 ¹ / ₂ " - 34"	199 lbs
APS2C		30 ¹ / ₂ " - 37" - 40 ¹ / ₂ "	224 lbs

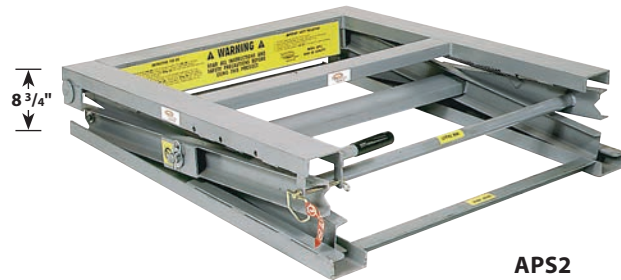

APS2
In Folded Position

**SEE PAGE 31
FOR REEL RACKS**

REEL WINDERS

HANDLE MATERIAL ON REELS QUICKLY AND EFFICIENTLY

Ideal for unreeling wire rope, cable and chain or almost anything that is stored on a reel. The structural channel frame has six roller positions to allow adjustment for virtually any reel diameter and is punched for floor mounting. The 2¹/₂" diameter rollers spin freely on ball bearing surfaces; side rollers ensure smooth pay off. A 10 ga. steel ramp permits safe on and off loading. The RW1 and RW2 are one piece units, the RW3 consists of two separate pieces. Orange enamel finish; ships via UPS.

• 4" HIGH X 28" LONG

MODEL NO.	NUMBER OF REELS	MAXIMUM REEL WIDTH	WIDTH	CAPACITY	WEIGHT
RW1	1	28"	31 ¹ / ₂ "	1500 lbs	73 lbs
RW2	1 or 2	48" or 24"	52"	3000 lbs	114 lbs
RW3	1	Unlimited	9 ¹ / ₄ "		79 lbs



RW1



RW3

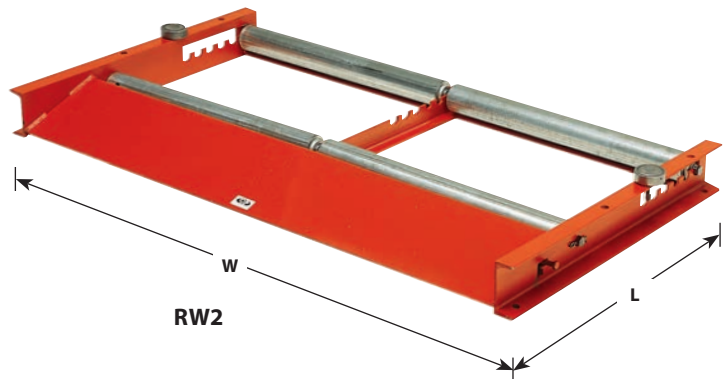

RW2



FORKLIFT PLATFORMS

USED WITH A FORKLIFT TO REACH HIGH PLACES SAFELY

Perform maintenance projects and order picking safely with a **MECO OMAHA** Forklift Platform. The non-slip floor plate deck is surrounded by a 4" toe plate to contain loose objects. Units are held securely to lift truck by a safety chain; 42" high side rails and positive locking gate keep worker safe. Worker is separated from vehicle by expanded metal screen. Full length 2 3/4" x 8" fork pockets ensure easy fork entry and exit.

Platforms can be customized with optional 3" casters for mobility, tool trays to keep parts and tools at worker's fingertips, 24" and 84" high bolt-on riser screens and a tube and bulb caddy to contain long parts requiring on-end storage. Casters provide 1000 lb. capacity and increase overall height of unit by 4 1/2".

• YELLOW ENAMEL FINISH • SHIPS KNOCKED DOWN

MODEL NO.	PLATFORM (W x D)	HEIGHT	FORK POCKET SPACING	WEIGHT
MPL1	36" x 32"	45"	16 1/4" Centers 8" Apart	152 lbs
MPL2	36" x 36"			163 lbs
MPL3	36" x 48"			198 lbs
MPL4	48" x 40"		28 1/4" Centers 20" Apart	207 lbs
MPL5	48" x 48"			230 lbs

• FORKLIFT PLATFORM ACCESSORIES

MODEL NO.	DESCRIPTION	WEIGHT
CK3P	Four 3" Polyolefin Swivel Casters	8 lbs
TT36	Tool Tray - 36" wide	7 lbs
TT48	Tool Tray - 48" wide	9 lbs
BCR36	24" Riser Screen - 36" wide	16 lbs
BCR48	24" Riser Screen - 48" wide	22 lbs
BCR36-84	84" Riser Screen - 36" wide	29 lbs
BCR48-84	84" Riser Screen - 48" wide	36 lbs
FBC	Tube and Bulb Caddy	19 lbs

MECO OMAHA FORKLIFT PLATFORMS CONFORM TO ANSI/ITSDF STANDARD B56.1-2012.



MPL3
With Optional
CK3P Caster Kit

MPL3
With Optional
Riser Screen (BCR36),
Tube Caddy (FBC),
Tool Tray (TT36)
and Casters (CK3P)



FORKLIFT STOCK PICKER

ACCOMMODATES PALLETS TO 42" DEEP

This narrow-aisle work platform excels as an aerial stock picker. The expanded metal screen extends 84" above the deck shielding the worker from the forklift mechanism. A mast chain secures the stock picker to the forklift. Man-on-board is restrained by a double safety chain and 42" high guard rails.

A 4" toe plate surrounds the non-slip floor plate deck. Forklift entry is easy with the exclusive **MECO OMAHA** tapered fork pocket design. 3" x 5 1/2" fork pockets taper to 2" x 3 1/2" and are mounted on 23" centers; 17" between pockets.

• YELLOW ENAMEL FINISH • SHIPS KNOCKED DOWN

MODEL NO.	PLATFORM (W x D)	OVERALL DEPTH	OVERALL HEIGHT	WEIGHT
FSP1	29" x 20"	60"	87"	256 lbs

TOTAL WEIGHT OF WORKER AND LOAD NOT TO EXCEED 1000 LBS.



FSP1



BAR CRADLE TRUCKS

FOR EASY HANDLING OF BAR STOCK, PIPE AND TUBING

Framed with structural channel, this truck is as rock solid as it looks. The 3" wide cradles are supported by structural channel on the bottom and both sides. Cradles are 24" across and 13" deep to accept large bundles of stock.

The 12" phenolic load wheels are known for exceptional strength and resistance to oil, gasoline and most commonly used solvents and chemicals. Eight inch swivel caster at each end and a tilt pattern permit the truck to turn in its own radius. All wheels have roller bearings.

Capacities based on evenly distributed loads. Gray enamel finish.



BCT96-10

• ALL TRUCKS ARE 28" WIDE x 29" HIGH

MODEL NO.	CAPACITY	LENGTH	RUNNING GEAR	NO. OF CRADLES	WEIGHT
BCT60-4	4,000 lbs	60"	2 - 12" x 2 1/2" Phenolic Load Wheels 2 - 8" x 2" Polyolefin Swivel Casters	3	194 lbs
BCT96-4		96"			229 lbs
BCT60-10	10,000 lbs	60"	2 - 12" x 3" Phenolic Load Wheels 2 - 8" x 2" Phenolic Swivel Casters		248 lbs
BCT72-10		72"			262 lbs
BCT96-10		96"		4	316 lbs
BCT120-10		120"			423 lbs
BCT144-10		144"			483 lbs

NOT TO BE USED ON RAMPS, SLOPES OR INCLINED SURFACES.

BAR STORAGE TRUCKS

ALL-SWIVEL CASTERS PROVIDE MAXIMUM MANEUVERABILITY IN TIGHT QUARTERS

Transport bundles of steel, pipe, tube, lumber or any other long, heavy material with the **MECO OMAHA** Bar Storage Truck. Loads are safely contained by six structural channel posts. The 4" structural channel frame handles loads to 5600 lbs. Deck height is a convenient 16"; all wheels have roller bearings. Gray enamel finish.



BST-SS

• 5600 LB CAPACITY

MODEL NO.	WIDTH	LENGTH	SWIVEL CASTERS	WEIGHT
BST-PH	24"	84"	8" x 2" Phenolic	242 lbs
BST-SS			8" x 2" Steel	240 lbs

PANEL MOVERS FOR NO-HASSLE TRANSPORT OF PANELS, SHEETS AND BUILDING MATERIALS

A hefty 12 ga. steel frame supports long, bulky items that must be moved on edge. The PM1 consists of an all-steel frame; the PM2 has two non-slip carpeted cross battens to protect fragile items. Three removable U-rails provide two 11 1/2" wide load bays, rails extend 27 1/2" above the PM1 frame and 26" above the PM2 frame. Both units ship knocked down in a carton via UPS. Gray enamel finish with galvanized steel U-rails. All-swivel casters are bolted to the frame for easy replacement.

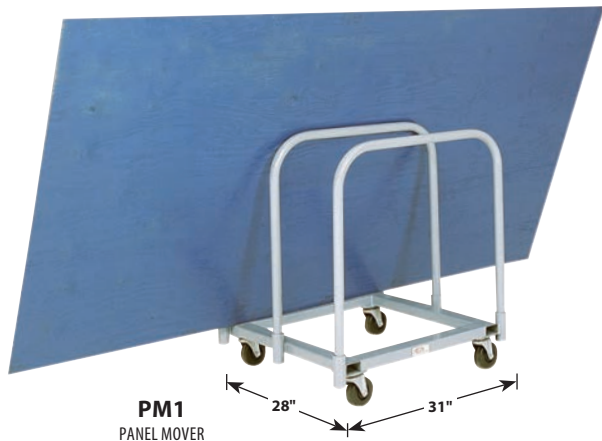

PM1
PANEL MOVER

• 900 LB CAPACITY

MODEL NO.	FRAME	LENGTH	WIDTH	HEIGHT	SWIVEL CASTERS	WEIGHT
PM1	Steel	31"	28"	34"	4" Hard Rubber	61 lbs
PM2	Carpeted					65 lbs



SELF DUMPING HOPPERS

WELDED WATERTIGHT. VERSATILE HOPPERS ARE EXCELLENT FOR HANDLING HEAVY, BULKY SCRAP, IN-PROCESS MATERIALS, CASTINGS, WOOD AND METAL CHIPS, RECYCLABLES AND SLUDGE

These rugged, welded steel hoppers solve your bulk handling problems and increase productivity—low cost means quick payback! Hoppers are designed for forklift handling, dump safely from any height and are precisely balanced to tip forward for complete discharge of contents and return to an upright position. For wet or dry use. A positive locking latch prevents accidental dumping; 2" formed top lips increase rigidity and eliminate sharp edges. A safety chain secures the hopper to the handling vehicle. Empty units through 2 cubic yard size can be stacked up to 3 high for space savings (not to be stacked when loaded). Hoppers are shipped fully assembled; choice of colors: orange or gray enamel (hoppers will be painted orange unless suffix "-G" is added to the model number).

Choose the Extra Heavy Duty hoppers for the most demanding applications. Heavy Duty hoppers and Medium Duty hoppers are available for loads that don't require the capacity of the Extra Heavy Duty models. Empty units through 2 cubic yards can be interstacked up to 3 high with heavier or lighter models of like size. Dimensions represent the overall width, length and height.

EXTRA HEAVY DUTY HOPPERS • 7 GA. STEEL / 7 GA. BASE

MODEL NO.	SIZE (CU. YDS.)	CAPACITY	DIMENSIONS			FORK OPENINGS		WEIGHT
			W	L	H	H	W	
SDHX025	1/4	6000 lbs	29"	49 1/2"	26"	2 1/2"	18 1/2"	368 lbs
SDHX033	1/3			53"	30 1/2"			406 lbs
SDHX050	1/2		41"	59 1/2"	34 1/2"		30 1/2"	486 lbs
SDHX075	3/4			59 1/2"	34 1/2"		542 lbs	
SDHX100	1		59"	63 1/2"	38 1/2"		48 1/2"	596 lbs
SDHX150	1 1/2			63 1/2"	38 1/2"		731 lbs	
SDHX200	2	72"	69 1/2"	44"	39"	826 lbs		
SDHX250	2 1/2*		69 1/2"	44"	955 lbs			
SDHX300	3*	5000 lbs	64"	74"	59 1/2"	39"	1130 lbs	
SDHX400	4*	4000 lbs	84"				1293 lbs	
SDHX500	5*		100"				1404 lbs	

LOW PROFILE EXTRA HEAVY DUTY HOPPERS • 7 GA. STEEL / 7 GA. BASE

MODEL NO.	SIZE (CU. YDS.)	CAPACITY	DIMENSIONS			FORK OPENINGS		WEIGHT
			W	L	H	H	W	
SDHLP300	3*	5000 lbs	85"	69 1/2"	46"	2 1/2"	39"	1036 lbs
SDHLP350	3 1/2*		98 1/2"					1124 lbs

HEAVY DUTY HOPPERS • 10 GA. STEEL / 7 GA. BASE

MODEL NO.	SIZE (CU. YDS.)	CAPACITY	DIMENSIONS			FORK OPENINGS		WEIGHT
			W	L	H	H	W	
SDHH025	1/4	4000 lbs	29"	49 1/2"	26"	2 1/2"	18 1/2"	331 lbs
SDHH033	1/3			53"	30 1/2"			359 lbs
SDHH050	1/2		41"	59 1/2"	34 1/2"		30 1/2"	428 lbs
SDHH075	3/4			59 1/2"	34 1/2"		471 lbs	
SDHH100	1		59"	63 1/2"	38 1/2"		48 1/2"	514 lbs
SDHH150	1 1/2			63 1/2"	38 1/2"		627 lbs	
SDHH200	2	72"	69 1/2"	44"	39"	699 lbs		
SDHH250	2 1/2*		69 1/2"	44"	807 lbs			
SDHH300	3*	64"	74"	59 1/2"		952 lbs		

MEDIUM DUTY HOPPERS • 12 GA. STEEL / 7 GA. BASE

MODEL NO.	SIZE (CU. YDS.)	CAPACITY	DIMENSIONS			FORK OPENINGS		WEIGHT
			W	L	H	H	W	
SDHM025	1/4	2000 lbs	29"	49 1/2"	26"	2 1/2"	18 1/2"	296 lbs
SDHM033	1/3			53"	30 1/2"			318 lbs
SDHM050	1/2		41"	59 1/2"	34 1/2"		30 1/2"	379 lbs
SDHM075	3/4			59 1/2"	34 1/2"		415 lbs	
SDHM100	1		59"	63 1/2"	38 1/2"		48 1/2"	452 lbs
SDHM150	1 1/2			63 1/2"	38 1/2"		543 lbs	
SDHM200	2	72"	69 1/2"	44"	39"	603 lbs		
SDHM250	2 1/2*		69 1/2"	44"	686 lbs			

* 2 1/2 YARD AND LARGER - NOT STACKABLE

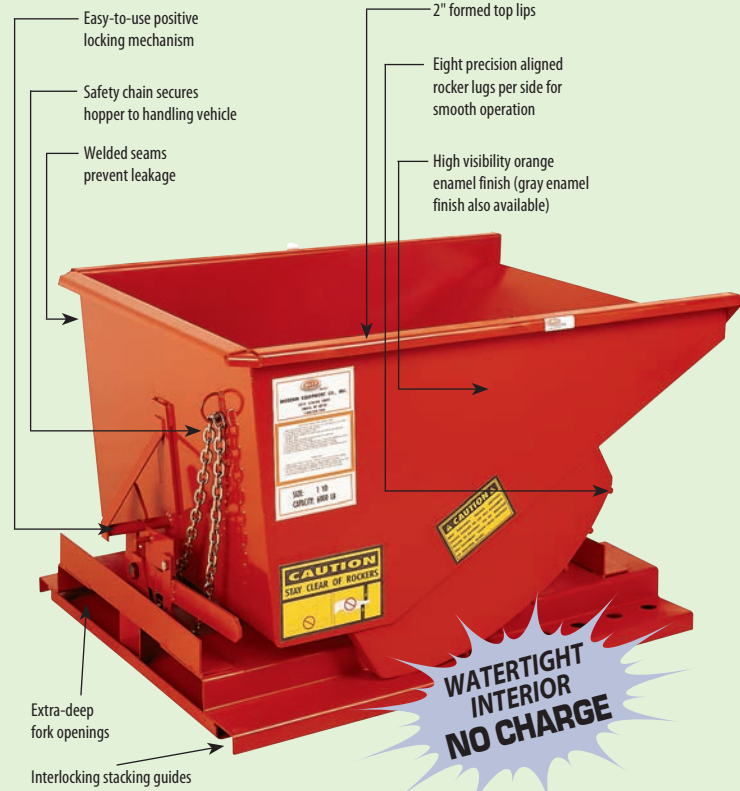

WATERTIGHT INTERIOR NO CHARGE

EASY FORKLIFT HANDLING



FOR GRAY ENAMEL FINISH, ADD SUFFIX "-G" TO MODEL NO.

SELF DUMPING HOPPER ACCESSORIES



HINGED LIDS for self dumping hoppers must be factory installed (prices include installation). One lid size fits Extra Heavy, Heavy, or Medium Duty hoppers. Painted orange or gray (lids will be painted orange unless suffix “-G” is added to the model number). Hoppers with lids are not stackable. The addition of a lid may alter the operation of the hopper. Please specify type A, B or C as set forth below. Indicate the type as a suffix to the model number. Example: HL100A or HL100A-G.

Add **CASTERS** to your hopper for mobility and free your valuable fork truck. Casters are available for hopper sizes through 2 1/2 cubic yards—6" or 8" diameter—in a two swivel/two rigid combination. All wheels have roller bearings; swivel casters have hardened double-ball raceway and 3/4" kingpin. Hoppers are shipped with casters bolted to the base; casters may be field installed.

OTHER POPULAR ACCESSORIES such as **3-way entry**, **platform legs** and **trip chains** are available, please call your **MECO OMAHA** representative for prices and specifications. Hoppers with accessories are non-returnable.

HINGED LIDS and CASTERS



• HINGED LIDS (NOT FOR USE WITH SERIES 90 HOPPERS)

MODEL NO.	HOPPER SIZE (CUBIC YARDS)	WEIGHT
HL025	1/4	50 lbs
HL033	1/3	55 lbs
HL050	1/2	75 lbs
HL075	3/4	86 lbs
HL100	1	96 lbs
HL150	1 1/2	140 lbs
HL200	2	145 lbs
HL250	2 1/2	179 lbs
HL300	3	189 lbs
HL400	4	248 lbs

• CASTERS (SET OF 4)

MODEL NO.	WHEELS		CAPACITY (SET OF 4)	WEIGHT
	SIZE	COMPOSITION		
CK620VR	6" x 2"	Mold-On Rubber	1600 lbs	53 lbs
CK625VR	6" x 2 1/2"		2000 lbs	71 lbs
CK820VR	8" x 2"		2000 lbs	67 lbs
CK825VR	8" x 2 1/2"		2700 lbs	74 lbs
CK620SS	6" x 2"	Steel	4000 lbs	59 lbs
CK625SS	6" x 2 1/2"		6000 lbs	91 lbs
CK820SS	8" x 2"		4000 lbs	72 lbs
CK825SS	8" x 2 1/2"		6000 lbs	93 lbs
CK620PH	6" x 2"	Phenolic	4800 lbs	46 lbs
CK625PH	6" x 2 1/2"		6000 lbs	60 lbs
CK820PH	8" x 2"		5600 lbs	55 lbs
CK825PH	8" x 2 1/2"		6000 lbs	75 lbs
CK620PU	6" x 2"	Polyurethane	4000 lbs	56 lbs
CK625PU	6" x 2 1/2"		4400 lbs	76 lbs
CK820PU	8" x 2"		4000 lbs	74 lbs
CK825PU	8" x 2 1/2"		5300 lbs	79 lbs

When ordering a hinged lid for a self dumping hopper, please specify type A, B or C as set forth below. Indicate the type as a suffix to the model number. Example HL100A.

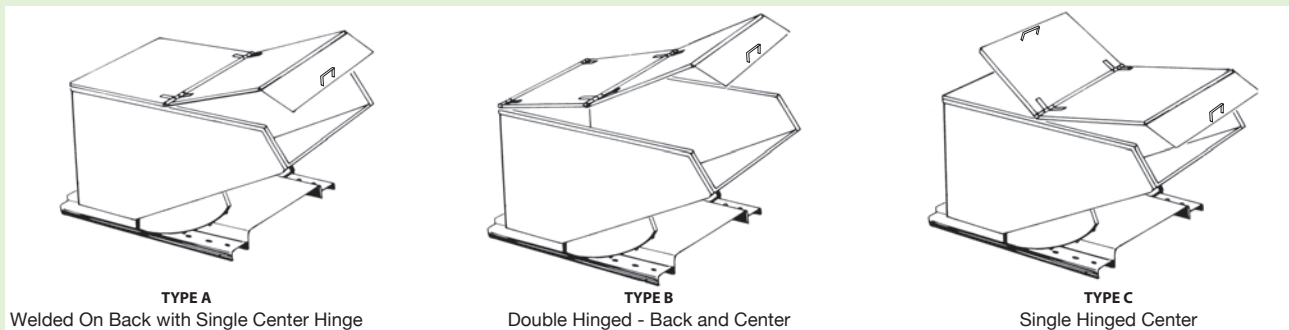

TYPE A
Welded On Back with Single Center Hinge

TYPE B
Double Hinged - Back and Center

TYPE C
Single Hinged Center



SERIES 90 SELF DUMPING HOPPERS

FULL 90° DUMP ANGLE FOR 100% DISCHARGE OF WET, VISCOUS MATERIALS. WELDED WATERTIGHT!

The Series 90 Self Dumping Hopper is designed for forklift handling. Easy dump release: while seated on forklift, operator simply pulls the dump cable to release the spring-loaded latch for a full 90° tilt. Hopper returns to an upright position when lowered to the ground. A positive locking mechanism prevents accidental dumping while a safety chain secures the hopper to the forklift.

Available in orange or gray enamel. Hoppers will be painted orange unless suffix "-G" is added to the model number.

Dimensions represent the overall width, length and height.

• EXTRA HEAVY DUTY HOPPERS • 7 GA. STEEL • 1/4" STEEL BASE

MODEL NO.	SIZE (CU. YDS.)	CAPACITY	DIMENSIONS			FORK OPENINGS		WEIGHT
			W	L	H	H	W	
SDHX025-90	1/4	6000 lbs	32"	55"	22"	2"	7"	233 lbs
SDHX050-90	1/2				29"			327 lbs
SDHX100-90	1		51"		41"	440 lbs		
SDHX150-90	1 1/2				41"	560 lbs		

• HEAVY DUTY HOPPERS • 10 GA. STEEL • 1/4" STEEL BASE

MODEL NO.	SIZE (CU. YDS.)	CAPACITY	DIMENSIONS			FORK OPENINGS		WEIGHT
			W	L	H	H	W	
SDHH050-90	1/2	4000 lbs	32"	55"	29"	2"	7"	267 lbs
SDHH100-90	1				51"			41"
SDHH150-90	1 1/2		41"			497 lbs		

• MEDIUM DUTY HOPPERS • 12 GA. STEEL • 1/4" STEEL BASE

MODEL NO.	SIZE (CU. YDS.)	CAPACITY	DIMENSIONS			FORK OPENINGS		WEIGHT
			W	L	H	H	W	
SDHM050-90	1/2	2000 lbs	32"	55"	29"	2"	7"	242 lbs
SDHM100-90	1				51"			41"
SDHM150-90	1 1/2		41"			473 lbs		

SERIES 90 HOPPERS ARE NOT STACKABLE.

• OPTIONAL CASTERS • TWO SWIVEL/TWO RIGID (SET OF 4)

MODEL NO.	WHEELS		CAPACITY (SET OF 4)	WEIGHT
	SIZE	COMPOSITION		
CK620VR-90	6" x 2"	Mold-On Rubber	1600 lbs	63 lbs
CK625VR-90	6" x 2 1/2"		2000 lbs	81 lbs
CK820VR-90	8" x 2"		2000 lbs	77 lbs
CK825VR-90	8" x 2 1/2"		2700 lbs	84 lbs
CK620SS-90	6" x 2"	Steel	4000 lbs	69 lbs
CK625SS-90	6" x 2 1/2"		6000 lbs	101 lbs
CK820SS-90	8" x 2"		4000 lbs	82 lbs
CK825SS-90	8" x 2 1/2"		6000 lbs	103 lbs
CK620PH-90	6" x 2"	Phenolic	4800 lbs	56 lbs
CK625PH-90	6" x 2 1/2"		6000 lbs	70 lbs
CK820PH-90	8" x 2"		5600 lbs	65 lbs
CK825PH-90	8" x 2 1/2"		6000 lbs	85 lbs
CK620PU-90	6" x 2"	Polyurethane	4000 lbs	66 lbs
CK625PU-90	6" x 2 1/2"		4400 lbs	86 lbs
CK820PU-90	8" x 2"		4000 lbs	84 lbs
CK825PU-90	8" x 2 1/2"		5300 lbs	89 lbs

HOPPERS ARE SHIPPED WITH CASTERS BOLTED TO THE BASE. CASTERS MAY BE FIELD INSTALLED.



**WATERTIGHT
INTERIOR
NO CHARGE**

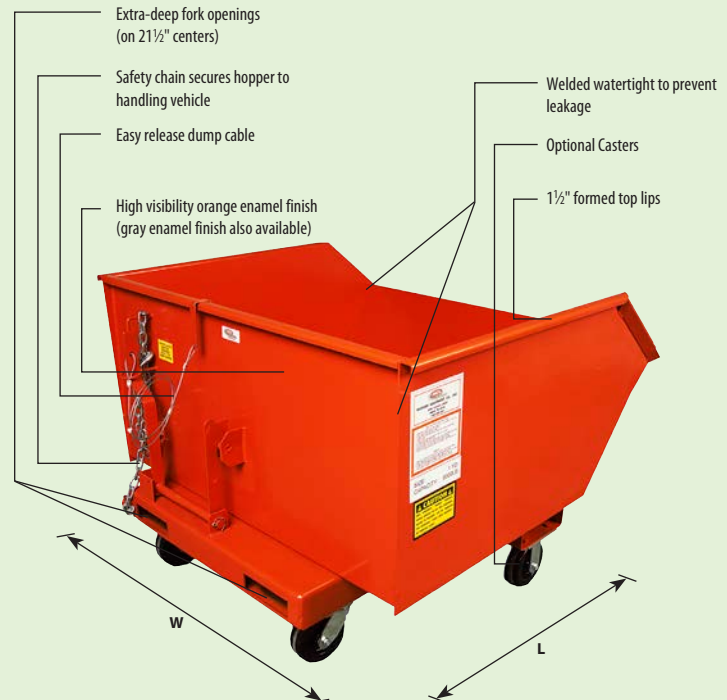



LO-PROFILE HOPPER TRUCKS

DESIGNED TO FIT UNDER PUNCH PRESSES, CONVEYORS and SIMILAR MACHINERY

- 5" X 2" Phenolic Casters in a 2 Swivel\2 Rigid Combination Provide 1000 lbs. of Capacity
- Sturdy Push Handle of 1" Diameter Tubing for Operating Ease
- Height From Floor to Lower Lip is a Comfortable 15½"
- Fabricated From 12 ga. Steel for Years of Use in an Industrial Environment



JK69

• INDUSTRIAL GRAY ENAMEL FINISH

MODEL NO.	SIZE CU. FT.	CAPACITY	OVERALL DIMENSIONS			WEIGHT
			LENGTH	WIDTH	HEIGHT	
JK69	6.9	1000 lbs.	36"	24"	35¼"	105 lbs.
JK96	9.6		42"	28"	35¼"	122 lbs.



STEEL TILT - HOPPER TRUCKS

WELDED WATERTIGHT AT NO ADDITIONAL CHARGE

- 5" X 2" Phenolic Casters in a 2 Swivel\2 Rigid Combination Provide up to 2000 lbs. of Capacity
- Heavy Duty Top and Bottom Handles Plus Reinforced Dumping Rocker Permit Controllable Two-Stage Dumping
- Manufactured From Industrial Grade 14 ga. Steel



KL58

• INDUSTRIAL GRAY ENAMEL FINISH

MODEL NO.	SIZE CU. FT.	CAPACITY	OVERALL DIMENSIONS			WEIGHT
			LENGTH	WIDTH	HEIGHT	
KL58	16.9	1000 lbs.	48"	24"	42½"	154 lbs.
KL1	27.0	1500 lbs.	59"	30"	41¼"	190 lbs.
KL15	40.5	2000 lbs.	60"	36"	47¼"	316 lbs.



CYLINDER STORAGE CABINETS

ORDERLY STORAGE AND PROTECTION OF INDUSTRIAL GAS CYLINDERS

Protect and store your cylinders in safety with our tamper-proof Cylinder Storage Cabinet. Steel cabinets are painted safety yellow for high visibility. Each cabinet is stenciled to indicate flammable storage. The steel cabinets are constructed of 13 gauge expanded metal sides with a solid 12 gauge steel top. Our **MECO OMAHA** designed padlock latch assembly allows you to easily secure your cylinders. The Cylinder Storage Cabinets feature foot plates punched for securing the unit to the floor. Cabinets conform to OSHA Subpart 1910.110 requirements and NFPA 58-79 standards. The all-steel cabinets ship either set up or knocked down.

• SET UP MODELS

HORIZONTAL STORAGE CABINETS FOR LP CYLINDERS					
MODEL NO.	NUMBER OF CYLINDERS	HEIGHT	WIDTH	DEPTH	WEIGHT
CSC4H	4	37"	32 1/2"	39"	164 lbs
CSC8H	8	70"			270 lbs
CSC12H	12		362 lbs		
CSC16H	16		65"	532 lbs	
VERTICAL STORAGE CABINETS FOR GAS CYLINDERS					
CSC1V	5 - 10	70"	32 1/2"	39"	215 lbs
CSC2V	10 - 20		65"		449 lbs

• SHIP KNOCKED DOWN IN A CARTON

HORIZONTAL STORAGE CABINETS FOR LP CYLINDERS					
MODEL NO.	NUMBER OF CYLINDERS	HEIGHT	WIDTH	DEPTH	WEIGHT
CSC4H-KD	4	37"	32 1/2"	39"	181 lbs
CSC8H-KD	8	70"			295 lbs
CSC12H-KD	12		49"	387 lbs	
CSC16H-KD	16		65"	532 lbs	
VERTICAL STORAGE CABINETS FOR GAS CYLINDERS					
CSC1V-KD	5 - 10	70"	32 1/2"	39"	228 lbs
CSC2V-KD	10 - 20		65"		413 lbs



CSC8H
HORIZONTAL STORAGE CABINET

CYLINDER STO



CSC2V
VERTICAL STORAGE CABINET



CSC1V
VERTICAL STORAGE CABINET



CYLINDER PALLET RACKS

SECURE, EASY STORAGE AND FORKLIFT MOBILITY

MECO OMAHA Cylinder Pallet Racks hold cylinders up to 9" in diameter securely in place for easy storage and mobility. Hinged dividers provide convenient access to individual cylinders from either end. Units are all double welded steel construction. 7 gauge steel fork pockets accommodate forks up to 6" wide allowing storage and delivery with your forklift. Select models with two swivel/two rigid casters for additional maneuverability. Ships completely assembled; orange enamel finish.



• 19 3/4" CLEARANCE REQUIRED BETWEEN FORKS

MODEL NO.	NUMBER OF CYLINDERS	HEIGHT	WIDTH	DEPTH	WEIGHT
CP4	4	41"	34"	23"	153 lbs
CP6	6			33"	200 lbs
CP8	8			43"	247 lbs

• WITH 4" HARD RUBBER CASTERS • 1500 LB CAPACITY

MODEL NO.	NUMBER OF CYLINDERS	HEIGHT	WIDTH	DEPTH	WEIGHT
CP4-C	4	46"	34"	23"	168 lbs
CP6-C	6			33"	215 lbs
CP8-C	8			43"	262 lbs

RAGE AND HANDLING EQUIPMENT

CYLINDER TRUCKS

EFFORTLESSLY MOVE 6 OR 8 HEAVY CYLINDER BOTTLES WITHOUT THE AID OF MECHANIZED EQUIPMENT

Choose a double welded **MECO OMAHA** Cylinder Truck to handle cylinders up to 9 1/4" in diameter. The 1/4" steel deck and 1" square tube superstructure are built for durability and years of service; a 3/4" diameter push handle provides comfortable operation. Cylinders are held safely in place by two heavy duty chains 37" above the deck. Both models roll smoothly on two swivel/two rigid phenolic casters, wheels have roller bearings.

A floor clearance of 1 1/2" on the **six cylinder model** makes loading and unloading easy; truck is held securely in place with a floor lock.

A 10" wide fold-down ramp on either side of the **eight cylinder model** allows cylinders to be loaded without effort. Brakes on the swivel casters keep truck stationary.

Ships assembled; orange enamel finish.

• 1500 LB CAPACITY

MODEL NO.	NUMBER OF CYLINDERS	WHEELS	HEIGHT	WIDTH	LENGTH	WEIGHT
CT-6	6	6" x 2" Phenolic	42"	24"	46"	181 lbs
CT-8	8	8" x 2" Phenolic			60 1/2"	291 lbs

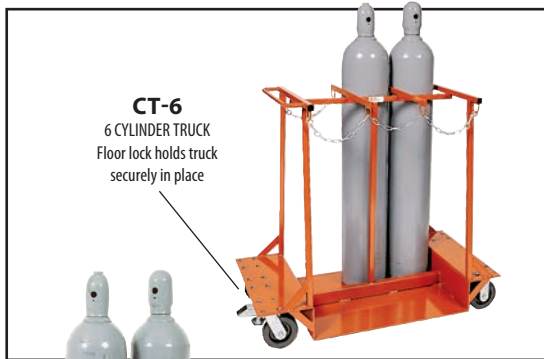



MACHINE, EQUIPMENT AND RACK GUARDS

PROVIDE PROTECTION FOR EXPENSIVE MACHINERY, RACK SYSTEMS AND PERSONNEL

- Select Lo-Profile, Hi-Profile or Corner Pipe Guards
- Manufactured from Hefty 4½" Diameter X 11ga. Wall Tubing
- ¼" X 8" X 8" Base Plate with Four 7⁄8" X 1¼" Slotted Holes for Secure Mounting
- Anchoring Hardware is NOT provided
- Yellow Powder Coat Finish for High Visibility
- Corner Pipe Guards with a 90° Bend Provide Excellent Protection to the Edge of Buildings

• LO-PROFILE PIPE GUARDS

MODEL NO.	HEIGHT	LENGTH	WEIGHT
LPPG936	9"	36"	53 lbs.
LPPG948		48"	65 lbs.
LPPG1636	16"	36"	69 lbs.
LPPG1648		48"	78 lbs.

• HI-PROFILE PIPE GUARDS

MODEL NO.	HEIGHT	LENGTH	WEIGHT
HPPG2436	24"	36"	58 lbs.
HPPG2448		48"	74 lbs.
HPPG3636	36"	36"	79 lbs.
HPPG3648		48"	87 lbs.
HPPG4236	*42"	36"	94 lbs.
HPPG4248		48"	97 lbs.

* 42" high models employ a 1½" diameter midrail for additional strength and protection.

• CORNER PIPE GUARDS

MODEL NO.	HEIGHT	LEG 1	LEG 2	WEIGHT
CPG2424	24"	24"	24"	74 lbs.
CPG2430		30"	30"	79 lbs.
CPG3624	36"	24"	24"	87 lbs.
CPG3630		30"	30"	93 lbs.
CPG4224	42"	24"	24"	95 lbs.
CPG4230		30"	30"	100 lbs.



CPG4224

STEEL SAFETY BOLLARDS

ELIMINATE IMPACT DAMAGE FROM MOTORIZED VEHICLES

- Available In Popular Heights of 24", 36" or 42"
- Select 4½" or 5½" Diameter Tubing for the Most Demanding Jobs - Both with 11 ga. Wall
- Removable Plastic Cap Allows Bollard to be Filled with Concrete for Maximum Strength
- ¼" X 8" X 8" Base Plate with Four 7⁄8" X 1¼" Slotted Holes for Secure Mounting
- Anchoring Hardware is NOT provided
- Yellow Enamel Finish for High Visibility



BOL4-5-24

• SAFETY BOLLARDS

MODEL NO.	HEIGHT	DIAMETER	WEIGHT
BOL4-5-24	24"	4½"	39 lbs.
BOL5-5-24		5½"	47 lbs.
BOL4-5-36	36"	4½"	50 lbs.
BOL5-5-36		5½"	62 lbs.
BOL4-5-42	42"	4½"	55 lbs.
BOL5-5-42		5½"	74 lbs.



SAFETY GUARDRAILS

MODULAR PANEL SYSTEM PERMITS STRAIGHT LINE OR 90° CORNERS

- Constructed of Heavy Wall 1½" Square Steel Tubing
- Safety Yellow Enamel Finish Provides High Visibility
- 48" Long Panels are 42" High with a Midrail for Additional Strength and Support
- Erect a Continuous Straight Line or 90° Guardrail System Using Intermediate Bases Between Panels and End Bases at the Start and Finish of the System
- Panel to Base Connecting Hardware is Included
- Optional Straight Panel and Corner Panel Tubular Connectors Provide Optimum Strength to the System
- Easy Installation - No Welding Required - Plastic End Caps on Top Rail - Anchoring Hardware NOT Provided

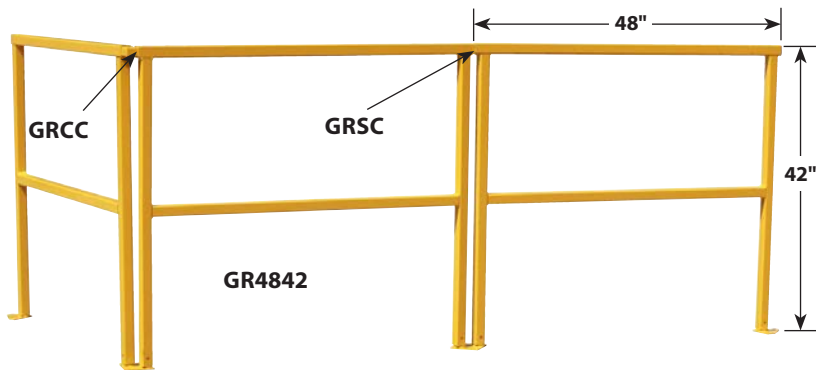

• ALL DOUBLE-WELDED COMPONENTS

MODEL NO.	DESCRIPTION	WEIGHT
GR4842	48" Railing Panel - 42" High	34 lbs.
GRIB	Intermediate Base Module	3 lbs.
GREB	End Base Module	2 lbs.
GRSC	Straight Panel Connector	1 lbs.
GRCC	Corner Panel Connector	2 lbs.

SQUARE TUBE SAFETY BOLLARDS

PROTECT PARKING AREAS, BUILDINGS AND IN-PLANT EQUIPMENT

- Available in Popular Heights of 24", 36" or 42"
- Fabricated From Heavy Wall 5" X 5" X 3/16" Square Steel Tubing
- ½" X 11" X 11" Base Plate is Pre-Drilled with Four Mounting Holes
- Anchoring Hardware NOT Provided
- Safety Yellow Enamel Finish for High Visibility, Topped with a Black Plastic Cap

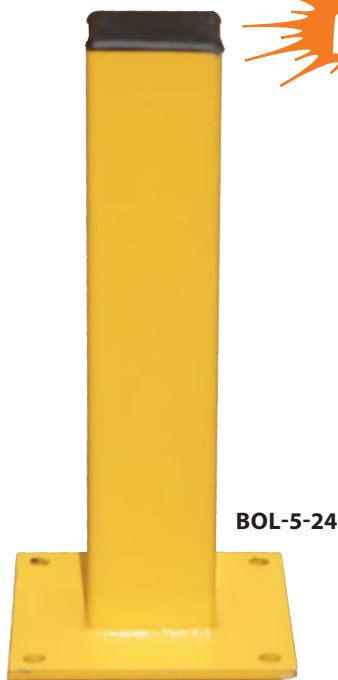

• SAFETY BOLLARDS

MODEL NO.	W x L	HEIGHT	WEIGHT
BOL-5-24	5" X 5"	24"	43 lbs.
BOL-5-36		36"	55 lbs.
BOL-5-42		42"	61 lbs.



PROTECTIVE BARRIERS

DESIGNED FOR THE MOST SEVERE GUARDING NEEDS

- Select Single, Double or Triple Rail Systems - Straight and Corner Barriers
- Corner Barriers are 42" Long Per Side
- Manufactured from Impact-Resistant 4" X 4" X 7 ga. Square Tubing
- All Joints Double-Welded
- ½" X 11" X 11" Base Plate with 7/8" Diameter Holes for Secure Mounting - Anchoring Hardware NOT Provided
- Plastic End Caps Provided on All Rails
- Safety Yellow Enamel Finish Provides High Visibility



• SINGLE RAIL SYSTEM

MODEL NO.	RAIL LENGTH	HEIGHT	WEIGHT
XRAS15-4	4'	15"	117 lbs.
XRAS15-6	6'		127 lbs.
XRAS15-8	8'		138 lbs.
XCGRS15	42"		155 lbs.



• DOUBLE RAIL SYSTEM

MODEL NO.	RAIL LENGTH	HEIGHT	WEIGHT
XRAD29.5-4	4'	29½"	190 lbs.
XRAD29.5-6	6'		211 lbs.
XRAD29.5-8	8'		232 lbs.
XCGRD29.5	42"		246 lbs.



• TRIPLE RAIL SYSTEM

MODEL NO.	RAIL LENGTH	HEIGHT	WEIGHT
XRAT44-4	4'	44"	215 lbs.
XRAT44-6	6'		270 lbs.
XRAT44-8	8'		326 lbs.
XCGRT44	42"		338 lbs.



MACHINERY AND RACK GUARDS

PROTECT EXPENSIVE MACHINERY FROM FORK TRUCKS AND POWERED EQUIPMENT

- Select Rail Heights of 10", 24" or 42" and Lengths of 36" or 48"
- Fabricated From Thick Wall 5" X 5" X 3/16" Steel Tubing
- ½" X 11" X 11" Base Plates Are Pre-Drilled with Four 7/8" Diameter Holes - Anchoring Hardware NOT Provided
- High Visibility Safety Yellow Enamel Finish
- Double-Welded Construction



• SHIP SET UP - READY FOR USE

MODEL NO.	RAIL LENGTH	HEIGHT	WEIGHT
MRG-1036	36"	10"	75 lbs.
MRG-1048	48"		87 lbs.
MRG-2436	36"	24"	103 lbs.
MRG-2448	48"		115 lbs.
MRG-4236	36"	42"	140 lbs.
MRG-4248	48"		152 lbs.

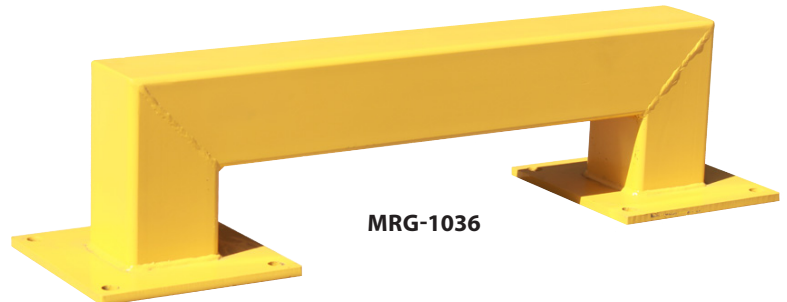



MODULAR PROTECTIVE RAILING SYSTEM

RAILS BOLT IN PLACE AND CAN BE EASILY REMOVED WHEN NECESSARY

- Variety of Components Permits a Custom Rail System or Protective Enclosure
- Posts are Manufactured from Heavy Duty 4" X 4" X 7 ga. Square Tube
- Rails are Manufactured from Heavy Duty 3½" X 3½" X 7 ga. Square Tube
- Posts are Double-Welded to Oversize ½" X 11" x 11" Steel Base Plates with Pre-Drilled 7/8" Mounting Holes - Anchoring Hardware NOT provided
- Removable Rails Offer Access to Machinery for Repairs and Maintenance (Post to Rail Hardware is Included)
- Black Plastic End Caps Provided for All Post Tops
- Safety Yellow Enamel Finish

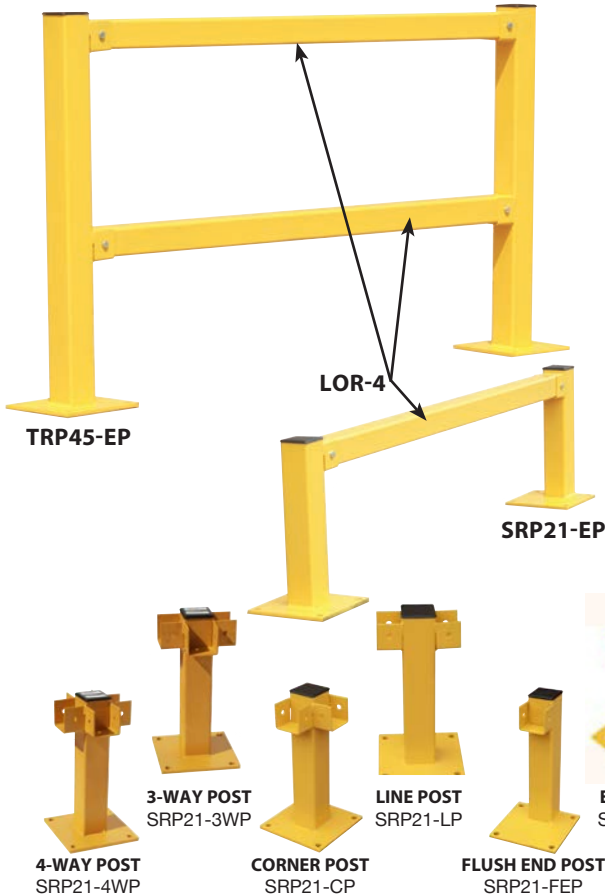

• LIFT-OUT RAILS

MODEL NO.	RAIL LENGTH	WEIGHT
LOR-4	4'	40 lbs.
LOR-6	6'	60 lbs.
LOR-8	8'	79 lbs.
LOR-10	10'	98 lbs.

• VERTICAL POSTS

DESCRIPTION	21" SINGLE RAIL POST		45" DOUBLE RAIL POST	
	MODEL NO.	WEIGHT	MODEL NO.	WEIGHT
END POST	SRP21-EP	38 lbs.	TRP45-EP	59 lbs.
FLUSH END POST	SRP21-FEP	39 lbs.	TRP45-FEP	60 lbs.
LINE POST	SRP21-LP	41 lbs.	TRP45-LP	64 lbs.
CORNER POST	SRP21-CP	42 lbs.	TRP45-CP	65 lbs.
3-WAY POST	SRP21-3WP	44 lbs.	TRP45-3WP	71 lbs.
4-WAY POST	SRP21-4WP	47 lbs.	TRP45-4WP	77 lbs.

PERIMETER GUARDS

FAST AND EASY ASSEMBLY - NO SPECIAL TOOLS REQUIRED

- Constructed of 2½" X 2½" X 14 ga. Square Tube Posts and Guard Panels of 1½" Expanded Metal
- Completely Modular - Create Long Runs or Enclosures Around Expensive Machinery
- Optional Gate Panels Provide Access Wherever Needed
- Easy Assembly - Simply Drop Panels Into Hook Fasteners On Posts and Secure With Provided Self-Tapping Screws
- Posts Have 4-Way Access for Versatility
- Safety Yellow Enamel Finish

• GUARD PANELS AND GATES

MODEL NO.	DESCRIPTION	HEIGHT	LENGTH	WEIGHT
WGS2424	PANEL	24"	24"	13 lbs.
WGS4824			48"	22 lbs.
WGS7224			72"	31 lbs.
WGS9624			96"	40 lbs.
WGS2460		60"	24"	26 lbs.
WGS4860			48"	42 lbs.
WGS7260	72"		58 lbs.	
WGS9660	GATE	24"	96"	74 lbs.
WGG4824			48"	32 lbs.
WGG4860				50 lbs.

• VERTICAL POSTS

MODEL NO.	POST HEIGHT	WEIGHT
WGP3-6	42"	10 lbs.
WGP6	72"	17 lbs.





MECO OMAHA's 200,000 sq. ft. facility
on ten acres of land in Omaha, Nebraska.



MODERN EQUIPMENT COMPANY, INC.

6161 Abbott Drive
Omaha, Nebraska 68110

PO Box 12278
Omaha, Nebraska 68112

E-mail: sales@meco-omaha.com • www.meco-omaha.com



LOCAL (402) 341-4939

ORDER TOLL FREE

1-800-228-7334

FAX 1-800-245-6078

WE NEVER MISS!
A PROMISED SHIPPING DATE